



FITTING INSTRUCTIONS FOR FE0337
LICENCE PLATE BRACKET



This kit contains the items pictured and labelled over page.
Some parts may be shown for clarity of instructions only.
Do not proceed until you are sure all parts are present.
Please read all instructions before proceeding.

IF IN ANY DOUBT WHEN FITTING OUR PRODUCTS, CONSULT ONE OF OUR DEALERS
OR HAVE FITTED BY A QUALIFIED TECHNICIAN.

Please note that the way the kit is packed does not necessarily represent the way of mounting to the bike.

In the event of rubber washers being used to hold components onto bolts, these rubber washers can be thrown away.

DIGITAL COPIES OF THESE INSTRUCTIONS ARE AVAILABLE FROM

[WWW.RG-RACING.COM](http://www.rg-racing.com)

R&G

Unit 1, Shelley's Lane, East Worldham, Alton, Hampshire, GU34 3AQ
Tel: +44 (0)1420 89007 Fax: +44 (0)1420 87301 www.rg-racing.com Email: info@rg-racing.com



<u>TOOLS REQUIRED</u>	<u>GENERAL TORQUE SETTINGS</u>
<ul style="list-style-type: none"> • Set of metric Allen keys (range from 3 to 6mm). • Set of metric sockets and ratchet (range from 8 to 14mm). • Small flat head screwdriver. • Long Phillips screwdriver. 	<p>M4 BOLT = 8Nm</p> <p>M5 BOLT = 12Nm</p> <p>M6 BOLT = 15Nm</p> <p>M8 BOLT = 20Nm</p> <p>M10 BOLT = 40Nm</p> <p>M12 BOLT = 40Nm</p>

LEGEND

ITEM No.	DESCRIPTION	QTY
ITEM 1	FE0337 PART 1	1
ITEM 2	FE0337 PART 2	1
ITEM 3	RG0038 (RUBBER GASKET)	2
ITEM 4	LA0002 (LICENSE PLATE ILLUMINATOR)	1
ITEM 5	M6 x 1.00 x 6mm BUTTON HEAD BOLT	2
ITEM 6	M5 x 0.80 x 12mm COUNTERSINK BOLT	2
ITEM 7	M6 x 12mm OD WASHER	2
ITEM 8	M5 x 10mm OD WASHER	2
ITEM 9	M5 NYLOC NUT	2
ITEM 10	FS0003BK (100mm SELF ADHESIVE FOAM)	1
ITEM 11	666-896 (200mm LENGTH OF HEAT-SHRINK)	1
ITEM 12	CON0014 (LICENSE PLATE ILLUMINATOR CONNECTOR)	1
ITEM 13	CT75 (2.5mm WIDE x 75mm LONG CABLE TIE)	3
ITEM 14	REFL 3 (REFLECTOR)	1

R&G

Unit 1, Shelley's Lane, East Worldham, Alton, Hampshire, GU34 3AQ

Tel: +44 (0)1420 89007 Fax: +44 (0)1420 87301 www.rg-racing.com Email: info@rg-racing.com



ASSEMBLY DIAGRAM

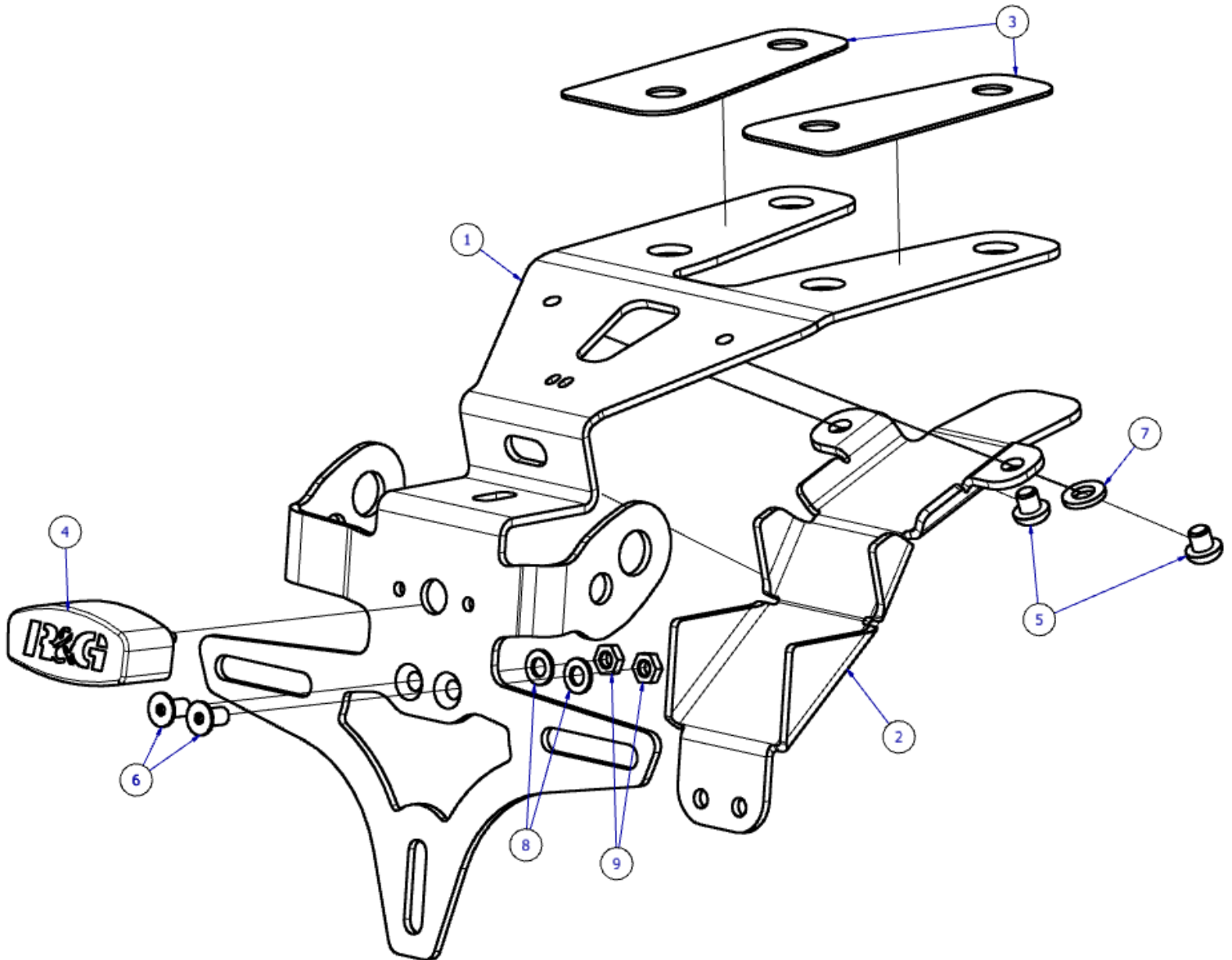

R&G

Unit 1, Shelley's Lane, East Worldham, Alton, Hampshire, GU34 3AQ

Tel: +44 (0)1420 89007 Fax: +44 (0)1420 87301 www.rg-racing.com Email: info@rg-racing.com



FITTING PICTURES



Picture 1



Picture 2



Picture 3



Picture 4

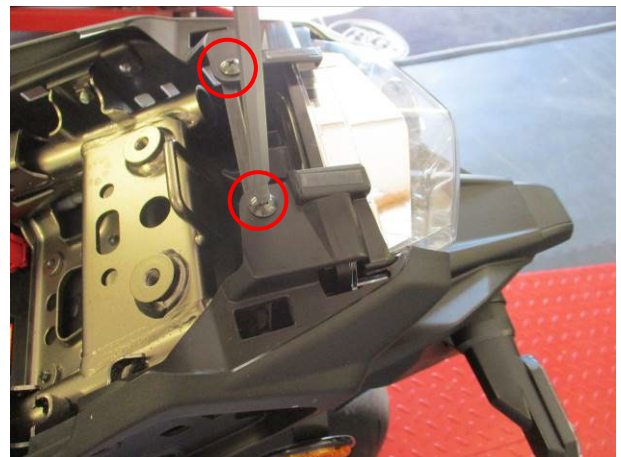



Picture 5

Picture 6



Picture 7

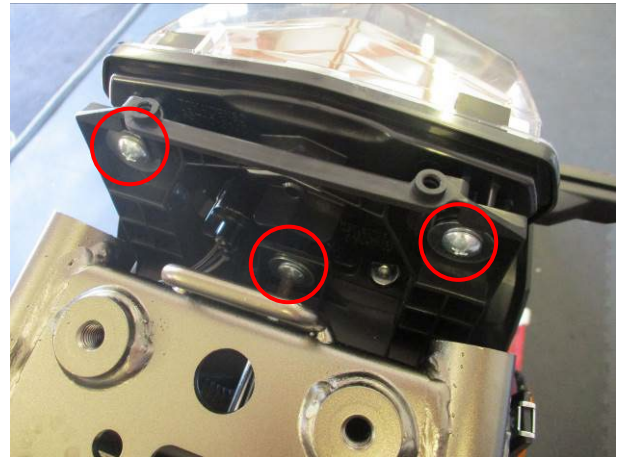

Picture 8



Picture 9



Picture 10

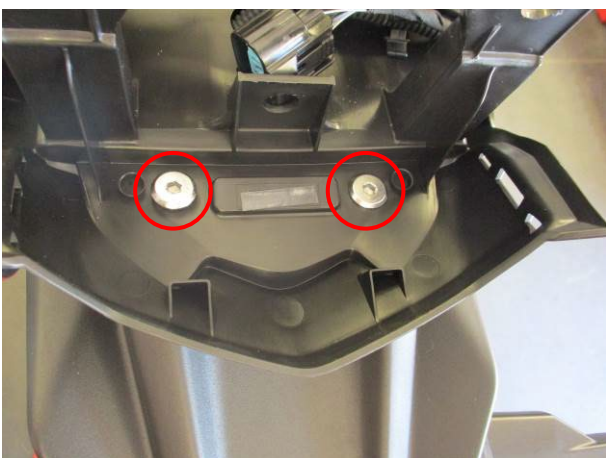

Picture 11



Picture 12

R&G

Unit 1, Shelley's Lane, East Worldham, Alton, Hampshire, GU34 3AQ

Tel: +44 (0)1420 89007 Fax: +44 (0)1420 87301 www.rg-racing.com Email: info@rg-racing.com

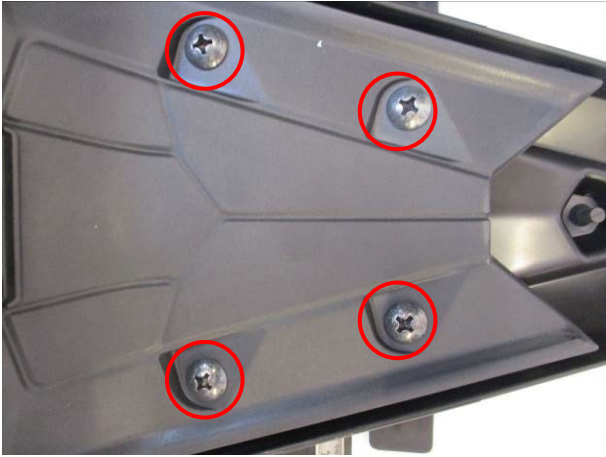

Picture 13

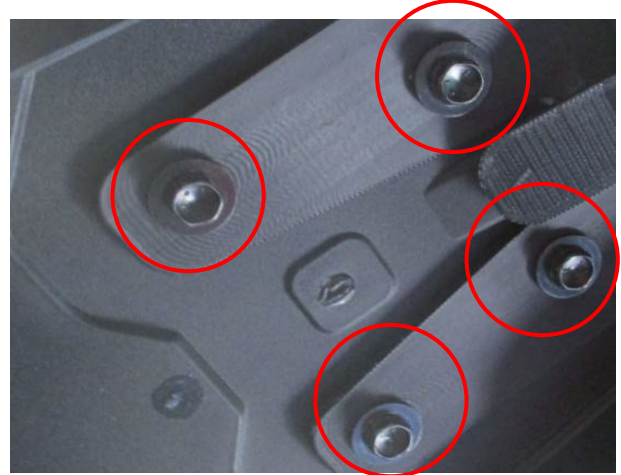

Picture 14

FITTING INSTRUCTIONS

Removal of OEM license plate bracket

- To begin with, remove the pillion seat by using the key slot as shown in **Picture 1**.
- As shown in **Picture 2**, remove the 4 x bolts and 2 x clips in order to remove the OEM grab rail.
- Carefully remove the black fairing panel shown in **Picture 3** by gently prying with a flat head screw driver for both the LHS and RHS.
- Remove the 3 x highlighted bolts from the LHS and 3 x highlighted cross head screws as shown in **Picture 3**, repeat this for the RHS as shown in **Picture 4**.
- Lift away the plastic trim as shown in **Picture 5**.
- Remove the black screws as highlighted in **Picture 6**.
- Remove the black screws as highlighted in **Picture 7**, now you can remove both LHS and RHS tail pieces.
- To remove the OEM tail light, which gives you access to 2 x mounting bolts, remove the 3 x highlighted screws shown in **Picture 8**, this will require a long Phillips screwdriver.
- Unplug the connector on the back of the brake light highlighted in **Picture 9**.
- Disconnect the indicator connectors and license plate illuminator as shown in **Picture 12**, indicator connectors are red and black, license plate illuminator connector is white.
- Now the bolts shown in **Picture 10** and **Picture 11** can be removed to allow the OEM tail bracket to be separated from the bike.

R&G

Unit 1, Shelley's Lane, East Worldham, Alton, Hampshire, GU34 3AQ

Tel: +44 (0)1420 89007 Fax: +44 (0)1420 87301 www.rg-racing.com Email: info@rg-racing.com



- Once completed removed from the bike, the OEM indicators are made accessible by removed the 4 x screws shown in **Picture 13**.

Installation of R&G Fender Eliminator

- Assemble **FE0337** as shown in the **Assembly Diagram** shown above.
- Connect CON0014 to the bike and the provided licence plate illuminator, ensuring all wires are covered with heat shrink provided.
- Present the built R&G Fender Eliminator up to the bike with the OEM Indicators attached re-using the OEM indicator mounting nut and bolt.
- Thread the cables from the indicator and licence plate illuminator through the correct hole on the bike under the pillion seat.
- Re-use the OEM tail bracket bolts which are highlighted in **Picture 14**.
- Tidy the cables up using the provided cover plate (**Item 2**).
- Apply self-adhesive foam (**Item 10**) to the inside of the cover plate if preferred (**Item 2**).
- Check all components are secure, and that indicators along with licence plate illuminator are operating correctly before riding.

Ensure that the wiring does not foul or become trapped during operation.

IMPORTANT: IF FITTING A FULL-SIZE LICENCE PLATE AND PLACING IT FAR DOWN ON THE LICENCE PLATE HANGER, THERE IS A SMALL CHANCE OF THE LICENCE PLATE HITTING THE BACK WHEEL UNDER HEAVY LOAD AND OVER LARGE BUMPS IN THE ROAD. IT IS YOUR RESPONSIBILITY TO CHECK FOR THIS POSSIBILITY AND TAKE AVOIDING ACTION. FAILURE TO CHECK THIS COULD RESULT IN SERIOUS INJURY.

ISSUE 1 - 12/09/2021 - (AO)

CONSUMER NOTICE

The catalogue description and any exhibition of samples are only broad indications of the Products and R&G may make design changes which do not diminish their performance or visual appeal and supplying them in such state shall conform to the order. The Buyer acknowledges no representation or warranty (other than as to title) has been given or will apply to the Products other than those in R&G's order or confirmation and the Buyer confirms it has chosen the Products as being of merchantable quality and suitable for its particular purposes. Where R&G fits the Products or undertakes other services it shall exercise reasonable skill and care and rectify any fault free of charge unless the workmanship has been disturbed. The Buyer is responsible for ensuring that the warranty on the motorcycle is not affected by the fitting of the Products. On return of any defective Products R&G shall at its option either supply a replacement or refund the purchase money but shall not be liable if the Products have been modified or used or maintained otherwise than in accordance with R&G's or manufacturer's instructions and good engineering practice or if the defect arises from accident or neglect. Other than identified above and subject to R&G not limiting its liability for causing death and personal injury, it shall not be liable for indirect or consequential loss and otherwise its liability shall be limited to the amounts paid by the Buyer for the Products or the fitting or service concerned. These terms do not affect the Buyer's statutory rights.

R&G RACING RETURNS POLICY (NON-FAULTY GOODS)

Returns must be pre-authorized (if not pre-authorized the return will be rejected). Goods may only be returned direct to us if they were purchased direct from us (customer must prove if necessary). Otherwise to be returned to original vendor. Goods must be in re-sellable condition, in the opinion of R&G Racing. All returns are subject to a 25% restocking and handling fee (25%

R&G

Unit 1, Shelley's Lane, East Worldham, Alton, Hampshire, GU34 3AQ

Tel: +44 (0)1420 89007 Fax: +44 (0)1420 87301 www.rg-racing.com Email: info@rg-racing.com



of the gross value exc. P&P – at the prevailing price at time of purchase). The customer must pay any and all carriage charges. No returns of discontinued products, unless within 14 days of purchase. This policy does not affect your statutory rights and does not refer to faulty goods.

R&G

Unit 1, Shelley's Lane, East Worldham, Alton, Hampshire, GU34 3AQ

Tel: +44 (0)1420 89007 Fax: +44 (0)1420 87301 www.rg-racing.com Email: info@rg-racing.com



NOTICE DE MONTAGE POUR FE0337
SUPPORT DE PLAQUE



CE KIT CONTIENT LES ARTICLES ILLUSTRÉS ET ÉTIQUETES SUR LA PAGE.

CERTAINES PARTIES PEUVENT ÊTRE PRÉSENTES UNIQUEMENT POUR LA CLARTÉ DES INSTRUCTIONS.

NE PAS PROCÉDER AU MONTAGE TANT QUE VOUS N'ÊTES PAS SÛR QUE TOUTES LES PIÈCES SOIENT PRÉSENTES.

VEUILLEZ LIRE TOUTES LES INSTRUCTIONS AVANT DE CONTINUER.

EN CAS DE DOUTE LORS DU MONTAGE DE NOS PRODUITS, CONSULTEZ UN DE NOS REVENDEURS OU FAITES APPEL À UN TECHNICIEN QUALIFIÉ.

VEUILLEZ NOTER QUE LA FAÇON DONT LE KIT EST EMBALLÉ NE REPRÉSENTE PAS NECESSAIREMENT LA MANIÈRE DE LE MONTER SUR LA MOTO.

SI DES RONDELLES EN CAOUTCHOUC SONT UTILISÉES POUR MAINTENIR LES COMPOSANTS SUR LES BOULONS, ELLES PEUVENT ÊTRE JETÉES.

NOTICE DISPONIBLE AU TÉLÉCHARGEMENT SUR :
WWW.RG-RACING.COM

R&G

Unit 1, Shelley's Lane, East Worldham, Alton, Hampshire, GU34 3AQ
Tel: +44 (0)1420 89007 Fax: +44 (0)1420 87301 www.rg-racing.com Email: info@rg-racing.com



<u>OUTILS REQUIS</u>	<u>VALEURS DE SERRAGE</u>
<ul style="list-style-type: none"> • Clés Allen (de 3 à 6mm). • Clé métrique (de 8 à 14mm). • Petit tournevis cruciforme. • Grand tournevis cruciforme . 	M4 BOULON = 8Nm M5 BOULON = 12Nm M6 BOULON = 15Nm M8 BOULON = 20Nm M10 BOULON = 40Nm M12 BOULON = 40Nm

LÉGENDE

ARTICLE No.	DESCRIPTION	QTÉ
ARTICLE 1	FEP0337 PARTIE 1	1
ARTICLE 2	FEP0337 PARTIE 2	1
ARTICLE 3	RG0038 (JOINT EN CAOUTCHOUC)	2
ARTICLE 4	LA0002 (FEU DE PLAQUE)	1
ARTICLE 5	M6 x 1.00 x 6mm BOULON	2
ARTICLE 6	M5 x 0.80 x 12mm BOULON	2
ARTICLE 7	M6 x 12mm RONDELLE	2
ARTICLE 8	M5 x 10mm RONDELLE	2
ARTICLE 9	M5 ÉCROU	2
ARTICLE 10	FS0003BK (100mm MOUSSE AUTOCOLLANTE)	1
ARTICLE 11	666-896 (200mm MANCHO THERMO RÉTRACTABLE)	1
ARTICLE 12	CON0014 (CONNECTEUR DE FEU DE PLAQUE)	1
ARTICLE 13	CT75 (2.5mm WIDE x 75mm COLLIER DE SERRAGE)	3
ARTICLE 14	REFL 3 (RÉFLECTEUR)	1

R&G

Unit 1, Shelley's Lane, East Worldham, Alton, Hampshire, GU34 3AQ

Tel: +44 (0)1420 89007 Fax: +44 (0)1420 87301 www.rg-racing.com Email: info@rg-racing.com



SCHÉMA D'ENSEMBLE

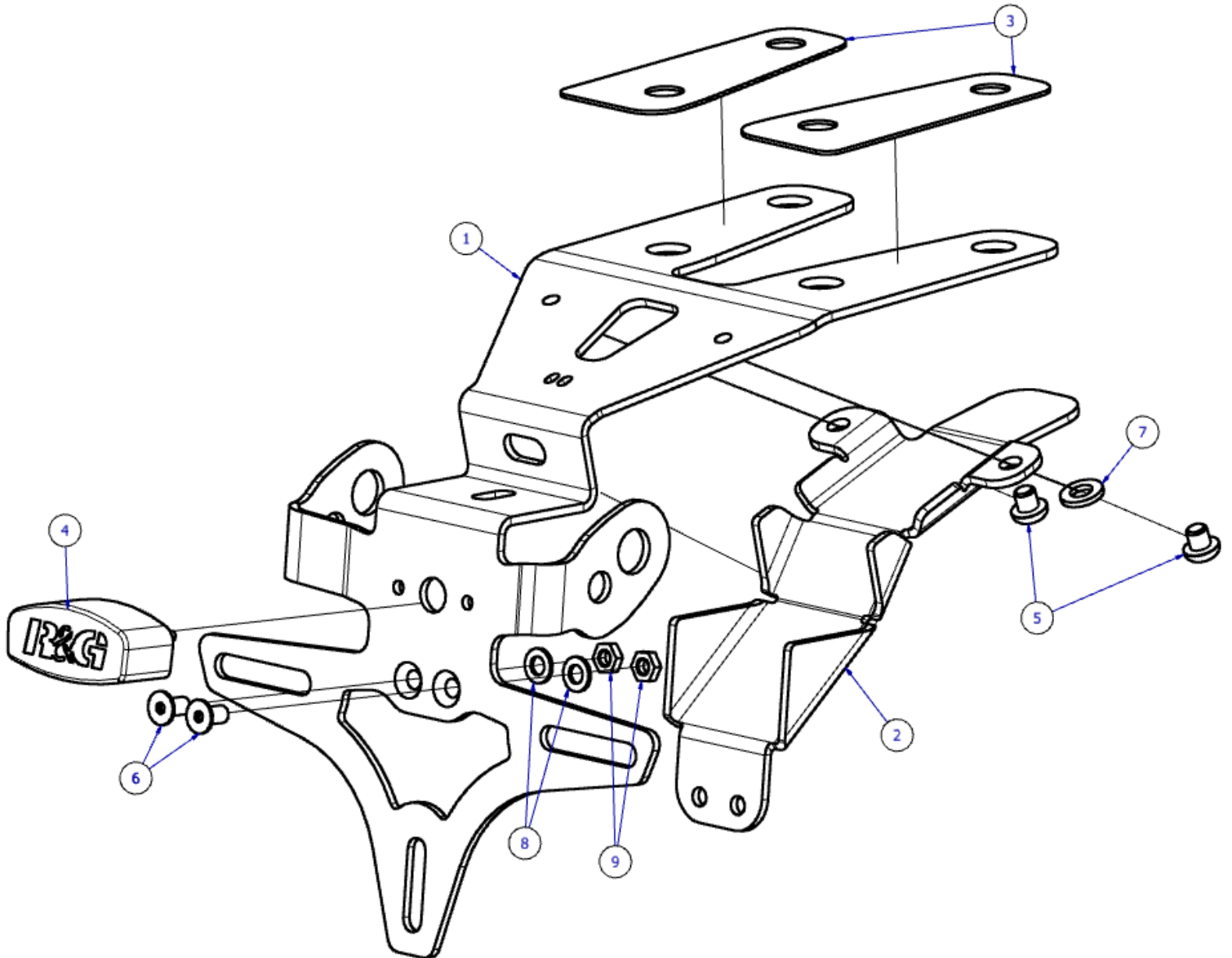

R&G

Unit 1, Shelley's Lane, East Worldham, Alton, Hampshire, GU34 3AQ

Tel: +44 (0)1420 89007 Fax: +44 (0)1420 87301 www.rg-racing.com Email: info@rg-racing.com



PHOTOS DE MONTAGE



Photo 1



Photo 2



Photo 3



Photo 4

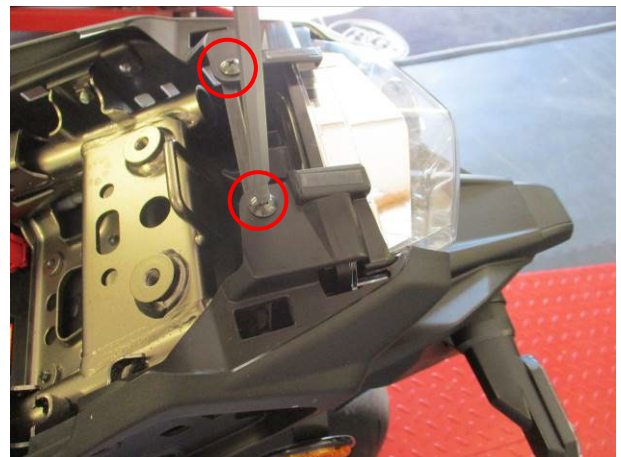



Photo 5



Photo 6

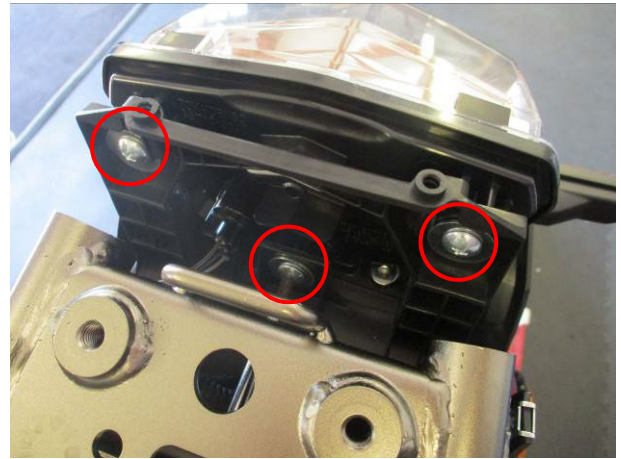

Photo 7



Photo 8



Photo 9



Photo 10



Photo 11

Photo 12

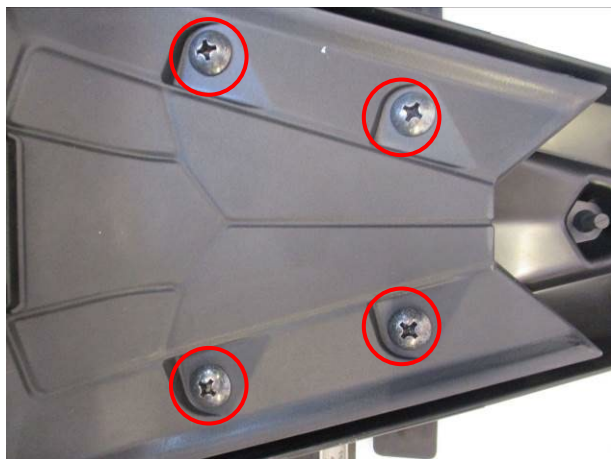

Photo 13



Photo 14

NOTICE DE MONTAGE

Retirer le support de plaque d'immatriculation d'origine

- Pour commencer, retirez la selle passager en utilisant la fente à clé comme indiqué sur la photo 1.
- Comme indiqué sur la Photo 2, retirez les 4 x boulons et 2 x clips afin de retirer la barre d'appui d'origine.
- Retirez délicatement le panneau de carénage noir illustré sur la photo 3 en faisant délicatement lever avec un tournevis à tête plate pour le côté gauche et le côté droit.
- Retirez les 3 boulons en surbrillance du côté gauche et les 3 vis à tête cruciforme en surbrillance comme indiqué sur la photo 3, répétez cette opération pour le côté droit comme indiqué sur la photo 4.
- Soulevez la garniture en plastique comme indiqué sur la Photo 5.
- Retirez les vis noires comme indiqué sur la Photo 6.
- Retirez les vis noires comme indiqué sur la photo 7, vous pouvez maintenant retirer les pièces de queue côté gauche et le côté droit.
- Pour retirer le feu arrière d'origine, qui vous donne accès à 2 x boulons de montage, retirez les 3 x vis en surbrillance illustrées sur la photo 8, cela nécessitera un long tournevis cruciforme.
- Débranchez le connecteur à l'arrière du feu stop mis en évidence sur la Photo 9.

R&G

Unit 1, Shelley's Lane, East Worldham, Alton, Hampshire, GU34 3AQ

Tel: +44 (0)1420 89007 Fax: +44 (0)1420 87301 www.rg-racing.com Email: info@rg-racing.com



- Débranchez les connecteurs des clignotants et le feu de plaque d'immatriculation comme indiqué sur la Photo 12, les connecteurs des clignotants sont rouges et noirs, le connecteur de feu de plaque d'immatriculation est blanc.
- Maintenant, les boulons illustrés sur la photo 10 et la photo 11 peuvent être retirés pour permettre de séparer le support d'origine de la moto.
- Une fois retirés de la moto, les clignotants d'origine sont rendus accessibles en retirant les 4 vis illustrées sur la photo 13.

Installation du garde-boue R&G

- Assemblez FE0337 comme indiqué sur le schéma d'assemblage ci-dessus.
- Connectez CON0014 à la moto et le feu de plaque d'immatriculation fourni, en vous assurant que tous les fils soient recouverts de la gaine thermo rétractable fournie.
- Présentez le garde-boue R&G intégré sur la moto avec les clignotants d'origine attachés en réutilisant l'écrou et le boulon de montage de clignotant d'origine.
- Faites passer les câbles de clignotant et de feu de la plaque d'immatriculation à travers le bon trou sur la moto sous la selle du passager.
- Réutilisez les boulons de support d'origine qui sont mis en évidence sur la Photo 14.
- Rangez les câbles à l'aide du cache fourni (article 2).
- Appliquez de la mousse autocollante (article 10) à l'intérieur de la plaque de recouvrement si vous préférez (article 2).
- Vérifiez que tous les composants soient sécurisés et que les clignotant ainsi que le feu de plaque d'immatriculation fonctionnent correctement avant de rouler.

Assurez-vous que le câblage ne s'encrasse pas ou ne se coince pas pendant le fonctionnement.

IMPORTANT : SI VOUS MONTEZ UNE PLAQUE D'IMMATRICULATION GRANDE TAILLE ET PLACEZ LA BIEN EN BAS SUR LE SUPPORT DE PLAQUE D'IMMATRICULATION, IL Y A UNE PETITE CHANCE QUE LA PLAQUE D'IMMATRICULATION FRAPPE LA ROUE ARRIÈRE SOUS UNE CHARGE LOURDE ET SUR DE GROSSES BOSSES SUR LA ROUTE. IL EST DE VOTRE RESPONSABILITÉ DE VÉRIFIER CETTE POSSIBILITÉ ET DE PRENDRE DES MESURES POUR L'ÉVITER. NE PAS VÉRIFIER CELA POURRAIT ENTRAÎNER DES BLESSURES GRAVES.

ISSUE 1 - 12/09/2021 - (AO)

CONSUMER NOTICE

The catalogue description and any exhibition of samples are only broad indications of the Products and R&G may make design changes which do not diminish their performance or visual appeal and supplying them in such state shall conform to the order. The Buyer acknowledges no representation or warranty (other than as to title) has been given or will apply to the Products other than those in R&G's order or confirmation and the Buyer confirms it has chosen the Products as being of merchantable quality and suitable for its particular purposes. Where R&G fits the Products or undertakes other services it shall exercise reasonable skill and care and rectify any fault free of charge unless the workmanship has been disturbed. The Buyer is responsible for

R&G

Unit 1, Shelley's Lane, East Worldham, Alton, Hampshire, GU34 3AQ

Tel: +44 (0)1420 89007 Fax: +44 (0)1420 87301 www.rg-racing.com Email: info@rg-racing.com



ensuring that the warranty on the motorcycle is not affected by the fitting of the Products. On return of any defective Products R&G shall at its option either supply a replacement or refund the purchase money but shall not be liable if the Products have been modified or used or maintained otherwise than in accordance with R&G's or manufacturer's instructions and good engineering practice or if the defect arises from accident or neglect. Other than identified above and subject to R&G not limiting its liability for causing death and personal injury, it shall not be liable for indirect or consequential loss and otherwise its liability shall be limited to the amounts paid by the Buyer for the Products or the fitting or service concerned. These terms do not affect the Buyer's statutory rights.

R&G RACING RETURNS POLICY (NON-FAULTY GOODS)

Returns must be pre-authorized (if not pre-authorized the return will be rejected). Goods may only be returned direct to us if they were purchased direct from us (customer must prove if necessary). Otherwise to be returned to original vendor. Goods must be in re-sellable condition, in the opinion of R&G Racing. All returns are subject to a 25% restocking and handling fee (25% of the gross value exc. P&P – at the prevailing price at time of purchase). The customer must pay any and all carriage charges. No returns of discontinued products, unless within 14 days of purchase. This policy does not affect your statutory rights and does not refer to faulty goods.

R&G

Unit 1, Shelley's Lane, East Worldham, Alton, Hampshire, GU34 3AQ

Tel: +44 (0)1420 89007 Fax: +44 (0)1420 87301 www.rg-racing.com Email: info@rg-racing.com



MONTAGEANLEITUNG FÜR FE0337
KENNZEICHENHALTER



Alle Kit-Teile sind auf den nachfolgenden Seiten abgebildet und gekennzeichnet.

Die abgebildeten Teile dienen lediglich zur Erklärung.

Überprüfen Sie zuerst, dass alle Teile vorhanden sind.

Lesen Sie die Montageanleitung komplett durch, bevor Sie anfangen.

**WENN SIE BEI DER MONTAGE DIESES PRODUKTES UNSICHER SIND, BITTE EINEN
UNSERER HÄNDLER KONTAKTIEREN ODER DAS KIT VON EINEM QUALIFIZIERTEN
ZWEIRAD-MECHANIKER MONTIEREN LASSEN.**

DIE VERPACKUNG DER TEILE STELLT NICHT DIE REIHENFOLGE DER MONTAGE DAR.

HINWEIS FÜR KITS MIT PLASTIKUNTERLEGSCHLEIBEN AN DEN SCHRAUBEN –
DIESE PLASTIK-UNTERLEGSCHLEIBEN WERDEN NICHT FÜR DEN EINBAU BENÖTIGT.

**EINE DIGITALE VERSION DIESER MONTAGEANLEITUNG KANN AUF FOLGENDER
SEITE HERUNTERGELADEN WERDEN:**

WWW.RG-RACING.COM

R&G

Unit 1, Shelley's Lane, East Worldham, Alton, Hampshire, GU34 3AQ
Tel: +44 (0)1420 89007 Fax: +44 (0)1420 87301 www.rg-racing.com Email: info@rg-racing.com



<u>SIE BENÖTIGEN FOLGENDES WERKEZEUG</u>	<u>ALLGEM. ANZUGSDREHMOMENT</u>
<ul style="list-style-type: none"> • Satz Inbusschlüssel (3 - 6mm) • Satz Steckschlüssel (8 - 14mm) • Kl. Flachklingen-Schraubenzieher • Kreuzschlitz-Schraubenzieher 	<p>M4 SCHRAUBE = 8Nm</p> <p>M5 SCHRAUBE = 12Nm</p> <p>M6 SCHRAUBE = 15Nm</p> <p>M8 SCHRAUBE = 20Nm</p> <p>M10 SCHRAUBE = 40Nm</p> <p>M12 SCHRAUBE = 40Nm</p>

LIEFERUMFANG

ARTIKEL NR.	BESCHREIBUNG	MENGE
ARTIKEL 1	FEP0337 TEIL 1	1
ARTIKEL 2	FEP0337 TEIL 2	1
ARTIKEL 3	RG0038 (GUMMIDICHTUNG)	2
ARTIKEL 4	LA0002 (KENNZEICHENBELEUCHTUNG)	1
ARTIKEL 5	M6 x 1.00 x 6mm INBUSSCHRAUBE	2
ARTIKEL 6	M5 x 0.80 x 12mm SENKSCHEIBE	2
ARTIKEL 7	M6 x 12mm OD UNTERLEGSCHNEIBE	2
ARTIKEL 8	M5 x 10mm OD UNTERLEGSCHNEIBE	2
ARTIKEL 9	M5 SELBSTSICHERNDE MUTTER	2
ARTIKEL 10	FS0003BK (100mm SELBSTKLEBENDER SCHAUMSTOFF)	1
ARTIKEL 11	666-896 (200mm SCHRUMPSCHLAUCH)	1
ARTIKEL 12	CON0014 (VERBINDUNG KENNZEICHENBELEUCHTUNG)	1
ARTIKEL 13	CT75 (2.5mm x 75mm KABELBINDER)	3
ARTIKEL 14	REFL 3 (RÜCKSTRAHLER)	1

R&G

Unit 1, Shelley's Lane, East Worldham, Alton, Hampshire, GU34 3AQ

Tel: +44 (0)1420 89007 Fax: +44 (0)1420 87301 www.rg-racing.com Email: info@rg-racing.com



ZEICHNUNG ZUSAMMENBAU

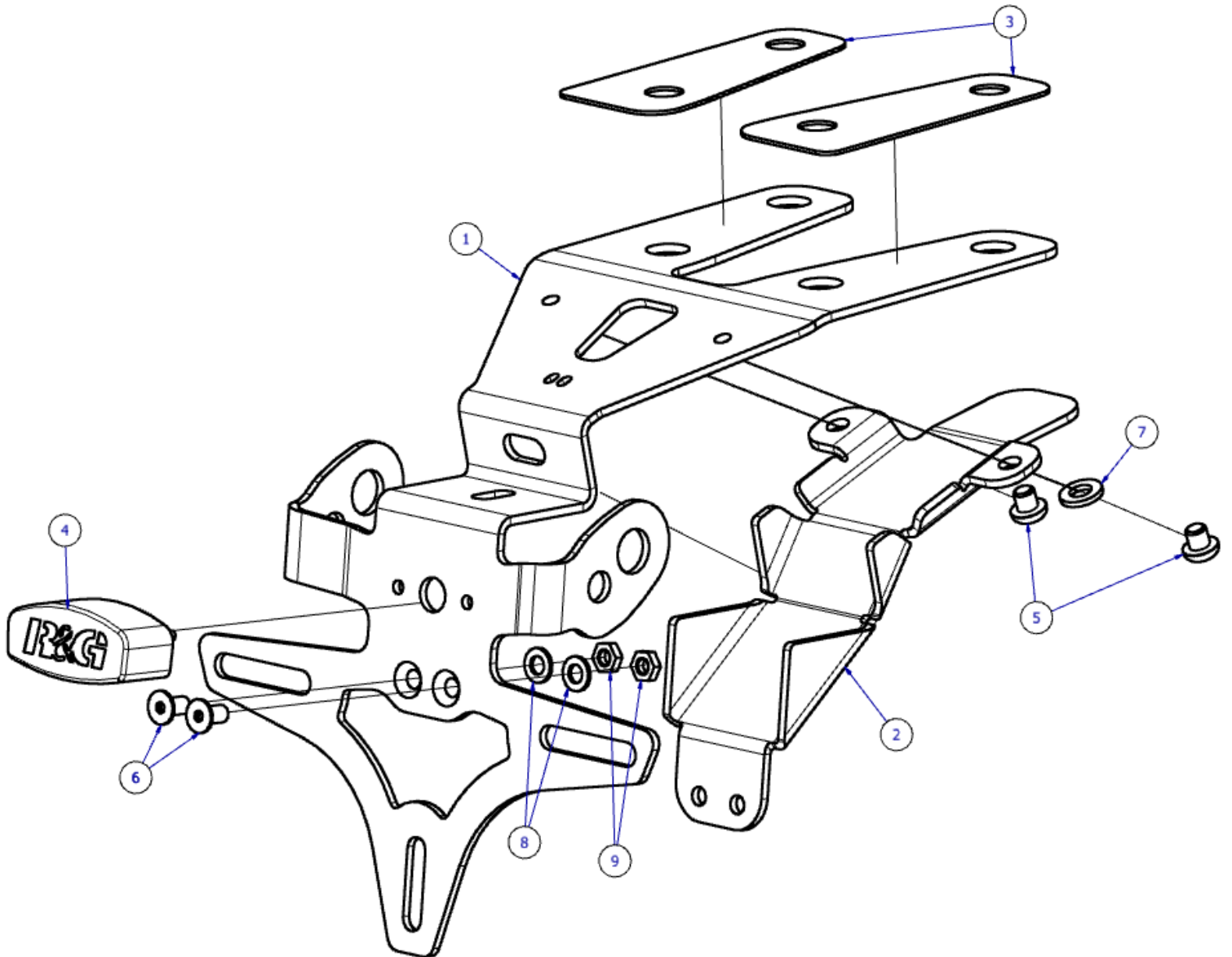

R&G

Unit 1, Shelley's Lane, East Worldham, Alton, Hampshire, GU34 3AQ

Tel: +44 (0)1420 89007 Fax: +44 (0)1420 87301 www.rg-racing.com Email: info@rg-racing.com



MONTAGE ABILDUNGEN



Abbildung 1



Abbildung 2



Abbildung 3



Abbildung 4



Abbildung 5



Abbildung 6

R&G

Unit 1, Shelley's Lane, East Worldham, Alton, Hampshire, GU34 3AQ

Tel: +44 (0)1420 89007 Fax: +44 (0)1420 87301 www.rg-racing.com Email: info@rg-racing.com



Abbildung 7



Abbildung 8



Abbildung 9

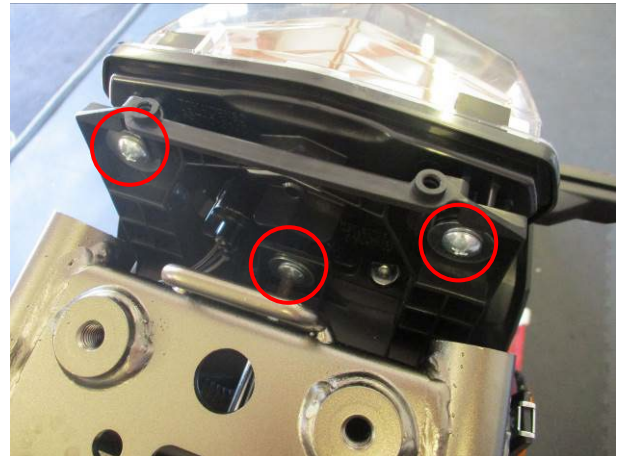

Abbildung 10



Abbildung 11



Abbildung 12

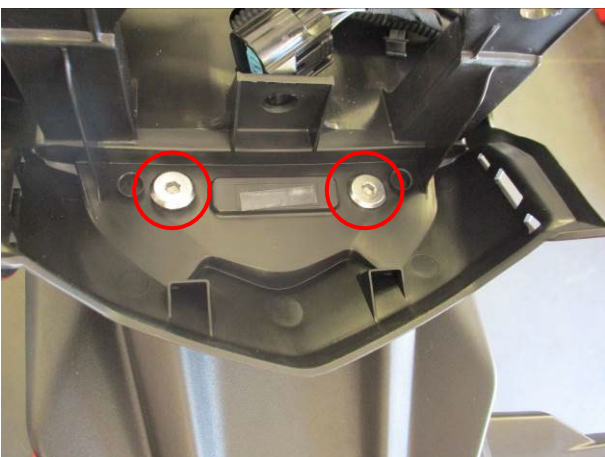

Abbildung 13



Abbildung 14

MONTAGEANLEITUNG

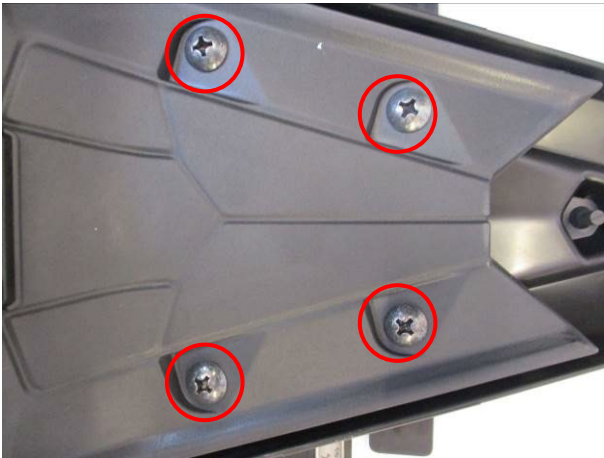
Entfernung des original Kennzeichenhalters

- Entfernen Sie zuerst den Beifahrersitz (Schlüssel wird hierfür benötigt) – siehe **Abbildung 1**.
- Wie in **Abbildung 2** abgebildet, entfernen Sie die 4 x Schrauben und 2 x Clips, um die original Haltegriffe zu entfernen.
- Entfernen Sie vorsichtig das schwarze Verkleidungsteil, welches in **Abbildung 3** abgebildet ist (mit einem Flachklingen-Schraubenzieher aushebeln an der rechten/linken Seite).
- Entfernen Sie die 3 x gekennzeichneten Schrauben an der linken Seite sowie die 3 x gekennzeichneten Inbusschrauben wie in **Abbildung 3** abgebildet und diesen Schritt an der rechten Seite wiederholen wie in **Abbildung 4** abgebildet.
- Entfernen Sie die Kunststoffabdeckung wie in **Abbildung 5** abgebildet.
- Entfernen Sie die schwarzen Schrauben, die in **Abbildung 6** markiert sind.
- Entfernen Sie die schwarzen Schrauben, die in **Abbildung 7** markiert sind – nun können Sie die Heckteile links und rechts entfernen.
- Um die original Kennzeichenbeleuchtung zu entfernen, und dadurch Zugang zu den 2 Montageschrauben zu bekommen, entfernen Sie die 3 markierten Schrauben, die in **Abbildung 8** abgebildet sind – hierzu benötigen Sie den langen Kreuzschlitz-Schraubendreher.
- Trennen Sie den Verbinder an der Rückseite der Kennzeichenbeleuchtung – siehe **Abbildung 9**.
- Trennen Sie die Verbinder für die Blinker und Kennzeichenbeleuchtung wie in **Abbildung 12** abgebildet - die Verbinder für die Blinker sind rot und schwarz, der Verbinder für die Kennzeichenbeleuchtung ist weiß.

R&G

Unit 1, Shelley's Lane, East Worldham, Alton, Hampshire, GU34 3AQ

Tel: +44 (0)1420 89007 Fax: +44 (0)1420 87301 www.rg-racing.com Email: info@rg-racing.com



- Jetzt können Sie die Schrauben entfernen, die in **Abbildung 10** und **Abbildung 11** abgebildet sind, um den original Kennzeichenhalter vom Motorrad abzumontieren.
- Nachdem der Kennzeichenhalter vom Motorrad entfernt wurde, können die Originalblinker abgebaut werden, indem die 4 Schrauben entfernt werden, die in **Abbildung 13** abgebildet sind.

Montage des R&G Kennzeichenhalters / Fender Eliminator

- **FE0337** zusammenbauen wie oben in **Zeichnung Zusammenbau** abgebildet.
- Verbinden Sie CON0014 mit dem Motorrad und der mitgelieferten Kennzeichenbeleuchtung – und stellen Sie sicher, dass alle Kabel mit dem Schrumpfschlauch vom Kit abgedeckt sind.
- Den zusammengebauten R&G Fender Eliminator mit den Originalblinkern ans Motorrad ansetzen – benutzen Sie die Befestigungsmutter und Schraube von den Originalblinkern wieder.
- Die Kabel für die Blinker und Kennzeichenbeleuchtung durch die richtige Öffnung am Motorrad unter dem Beifahrersitz fädeln.
- Benutzen Sie die Originalschrauben, die in **Abbildung 14** markiert sind.
- Die Kabel mittels der mitgelieferten Abdeckplatte (**Artikel 2**) ordentlich verstauen.
- Den selbstklebenden Schaumstoff (**Artikel 10**) an der Innenseite der Abdeckplatte (**Artikel 2**) anbringen, falls erforderlich/gewünscht.
- Überprüfen Sie, dass alle Komponente sicher befestigt sind und die Blinker und Kennzeichenbeleuchtung ordnungsgemäß funktionieren, bevor Sie mit dem Motorrad fahren.

Stellen Sie sicher, dass die Verkabelung nicht während der Fahrt eingeklemmt oder locker werden kann.

WICHTIG: WENN EIN GROSSES KENNZEICHEN ZU WEIT NACH UNTEN MONTIERT WIRD, BESTEHT BEI SCHWERER LAST ODER DURCH GROSSE BODENWELLEN EIN GERINGES RISIKO, DASS DAS KENNZEICHEN AN DAS HINTERRAD STOSSEN KANN. ES LIEGT IN IHRER VERANTWORTUNG DIES ZU ÜBERPRÜFEN UND, WENN NOTWENDIG, VORZUBEUGENDE MASSNAHMEN ZU ERGREIFEN. DIE NICHTBEACHTUNG DIESER SICHERHEITSHINWEISES KANN ZU SCHWEREN VERLETZUNGEN FÜHREN.

AUSGABE 1 - 12/09/2021 - (AO)

CONSUMER NOTICE

The catalogue description and any exhibition of samples are only broad indications of the Products and R&G may make design changes which do not diminish their performance or visual appeal and supplying them in such state shall conform to the order. The Buyer acknowledges no representation or warranty (other than as to title) has been given or will apply to the Products other than those in R&G's order or confirmation and the Buyer confirms it has chosen the Products as being of merchantable quality and suitable for its particular purposes. Where R&G fits the Products or undertakes other services it shall exercise reasonable skill and care and rectify any fault free of charge unless the workmanship has been disturbed. The Buyer is responsible for ensuring that the warranty on the motorcycle is not affected by the fitting of the Products. On return of any defective Products R&G shall at its option either supply a replacement or refund the purchase money but shall not be liable if the Products have been modified or used or maintained otherwise than in accordance with R&G's or manufacturer's instructions and good engineering practice or if the defect arises from accident or neglect. Other than identified above and subject to R&G not limiting its liability for causing death and personal injury, it shall not be liable for indirect or consequential loss and otherwise its liability

R&G

Unit 1, Shelley's Lane, East Worldham, Alton, Hampshire, GU34 3AQ

Tel: +44 (0)1420 89007 Fax: +44 (0)1420 87301 www.rg-racing.com Email: info@rg-racing.com



shall be limited to the amounts paid by the Buyer for the Products or the fitting or service concerned. These terms do not affect the Buyer's statutory rights.

R&G RACING RETURNS POLICY (NON-FAULTY GOODS)

Returns must be pre-authorized (if not pre-authorized the return will be rejected). Goods may only be returned direct to us if they were purchased direct from us (customer must prove if necessary). Otherwise to be returned to original vendor. Goods must be in re-sellable condition, in the opinion of R&G Racing. All returns are subject to a 25% restocking and handling fee (25% of the gross value exc. P&P – at the prevailing price at time of purchase). The customer must pay any and all carriage charges. No returns of discontinued products, unless within 14 days of purchase. This policy does not affect your statutory rights and does not refer to faulty goods.

R&G

Unit 1, Shelley's Lane, East Worldham, Alton, Hampshire, GU34 3AQ

Tel: +44 (0)1420 89007 Fax: +44 (0)1420 87301 www.rg-racing.com Email: info@rg-racing.com