



FITTING INSTRUCTIONS FOR FP0274



THIS KIT CONTAINS THE ITEMS PICTURED AND LABELLED OVER PAGE.

SOME PARTS MAY BE SHOWN FOR CLARITY OF INSTRUCTIONS ONLY.

DO NOT PROCEED UNTIL YOU ARE SURE ALL PARTS ARE PRESENT.

PLEASE READ ALL INSTRUCTIONS BEFORE PROCEEDING.

**IF IN ANY DOUBT WHEN FITTING OUR PRODUCTS, CONSULT ONE OF OUR DEALERS
OR HAVE FITTED BY A QUALIFIED TECHNICIAN.**

PLEASE NOTE THAT THE WAY THE KIT IS PACKED DOES NOT NECESSARILY REPRESENT THE WAY OF
MOUNTING TO THE BIKE.

IN THE EVENT OF RUBBER WASHERS BEING USED TO HOLD COMPONENTS ONTO BOLTS,
THESE RUBBER WASHERS CAN BE THROWN AWAY.

DIGITAL COPIES OF THESE INSTRUCTIONS ARE AVAILABLE FROM:

WWW.RG-RACING.COM



<u>TOOLS REQUIRED</u>	<u>GENERAL TORQUE SETTINGS</u>
<ul style="list-style-type: none"> • Socket set • Ratchet 	<p>M4 BOLT = 8Nm</p> <p>M5 BOLT = 12Nm</p> <p>M6 BOLT = 15Nm</p> <p>M8 BOLT = 20Nm</p> <p>M10 BOLT = 40Nm</p> <p>M12 BOLT = 40Nm</p>

LEGEND

ITEM NO.	DESCRIPTION	QTY
ITEM 1	SB0170 SPINDLE BAR	1
ITEM 2	B0442 M8 BOBBIN	2
ITEM 3	S1455 - RHS SPACER	1
ITEM 4	M8 NYLOC NUT	2
ITEM 5	M8x19mm WASHERS	2

ASSEMBLY DIAGRAM

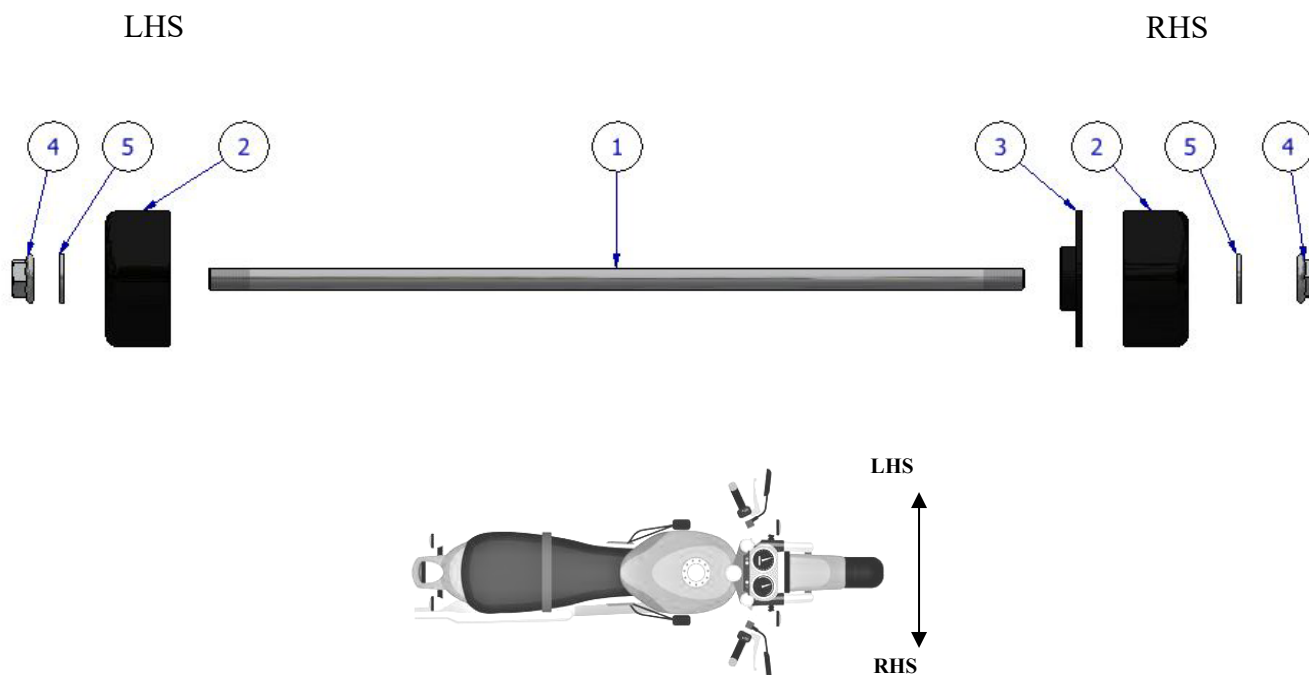



FITTING INSTRUCTIONS

- Slide the spindle bar (**ITEM 1**) through the hollow front spindle until the threaded part is visible on both sides.
- Place the spacer (**ITEM 3**) onto the RHS of the spindle bar (**ITEM 1**) and slot the shoulder of the spacer into the opening.
- Next place the bobbins (**ITEM 2**) over the spindle bar (**ITEM 1**) on both sides, ensuring the threaded part is still protruding through the bobbins.
- Secure the bobbins (**ITEM 2**) with the washers and nuts (**ITEM 4&5**) on both sides. Tighten with a 13mm socket on both sides, ensure to use the **GENERAL TORQUE SETTING** on page 2. Ensure both sides have an equal amount of thread engagement.

Use the **ASSEMBLY DIAGRAM** on page two for an example of how its assembled.

See more R&G products for your Motorcycle in the link below:

ISSUE 1 – 19/05/2023 (JH)

CONSUMER NOTICE

The catalogue description and any exhibition of samples are only broad indications of the Products and R&G may make design changes which do not diminish their performance or visual appeal and supplying them in such state shall conform to the order. The Buyer acknowledges no representation or warranty (other than as to title) has been given or will apply to the Products other than those in R&G's order or confirmation and the Buyer confirms it has chosen the Products as being of merchantable quality and suitable for its particular purposes. Where R&G fits the Products or undertakes other services it shall exercise reasonable skill and care and rectify any fault free of charge unless the workmanship has been disturbed. The Buyer is responsible for ensuring that the warranty on the motorcycle is not affected by the fitting of the Products. On return of any defective Products R&G shall at its option either supply a replacement or refund the purchase money but shall not be liable if the Products have been modified or used or maintained otherwise than in accordance with R&G's or manufacturer's instructions and good engineering practice or if the defect arises from accident or neglect. Other than identified above and subject to R&G not limiting its liability for causing death and personal injury, it shall not be liable for indirect or consequential loss and otherwise its liability shall be limited to the amounts paid by the Buyer for the Products or the fitting or service concerned. These terms do not affect the Buyer's statutory rights.

R&G RACING RETURNS POLICY (NON-FAULTY GOODS)

Returns must be pre-authorized (if not pre-authorized the return will be rejected). Goods may only be returned direct to us if they were purchased direct from us (customer must prove if necessary). Otherwise to be returned to original vendor. Goods must be in re-sellable condition, in the opinion of R&G Racing. All returns are subject to a 25% restocking and handling fee (25% of the gross value exc. P&P – at the prevailing price at time of purchase). The customer must pay any and all carriage charges. No returns of discontinued products, unless within 14 days of purchase. This policy does not affect your statutory rights and does not refer to faulty goods.

R&G Racing

Unit 1, Shelley's Lane, East Worldham, Alton, Hampshire, GU34 3AQ

Tel: +44 (0)1420 89007 Fax: +44 (0)1420 87301 www.rg-racing.com Email: info@rg-racing.com



NOTICE DE MONTAGE POUR FP0274



CE KIT CONTIENT LES ARTICLES ILLUSTRÉS ET ÉTIQUETES SUR LA PAGE.

CERTAINES PARTIES PEUVENT ÊTRE PRÉSENTES UNIQUEMENT POUR LA CLARTÉ DES INSTRUCTIONS.

NE PAS PROCÉDER AU MONTAGE TANT QUE VOUS N'ÊTES PAS SÛR QUE TOUTES LES PIÈCES SOIENT PRÉSENTES.

VEUILLEZ LIRE TOUTES LES INSTRUCTIONS AVANT DE CONTINUER.

EN CAS DE DOUTE LORS DU MONTAGE DE NOS PRODUITS, CONSULTEZ UN DE NOS REVENDEURS OU FAITES APPEL À UN TECHNICIEN QUALIFIÉ.

VEUILLEZ NOTER QUE LA FAÇON DONT LE KIT EST EMBALLÉ NE REPRÉSENTE PAS NECESSAIREMENT LA MANIÈRE DE LE MONTER SUR LA MOTO.

SI DES RONDELLES EN CAOUTCHOUC SONT UTILISÉES POUR MAINTENIR LES COMPOSANTS SUR LES BOULONS, ELLES PEUVENT ÊTRE JETÉES.

NOTICE DISPONIBLE AU TÉLÉCHARGEMENT SUR :

WWW.RG-RACING.COM

R&G Racing

Unit 1, Shelley's Lane, East Worldham, Alton, Hampshire, GU34 3AQ

Tel: +44 (0)1420 89007 Fax: +44 (0)1420 87301 www.rg-racing.com Email: info@rg-racing.com



<u>OUTILS REQUIS</u>	<u>VALEURS DE SERRAGE</u>
<ul style="list-style-type: none"> • Clé à cliquet • Douilles 	M4 BOULON = 8Nm M5 BOULON = 12Nm M6 BOULON = 15Nm M8 BOULON = 20Nm M10 BOULON = 40Nm M12 BOULON = 40Nm

LÉGENDE

ARTICLE NO.	DESCRIPTION	QTÉ
ARTICLE 1	SB0170 AXE	1
ARTICLE 2	B0442 M8 PROTECTION	2
ARTICLE 3	S1455 - ENTRETOISE CÔTÉ DROIT	1
ARTICLE 4	M8 ÉCROU	2
ARTICLE 5	M8x19mm RONDELLES	2

SCHÉMA D'ENSEMBLE

GAUCHE

DROIT

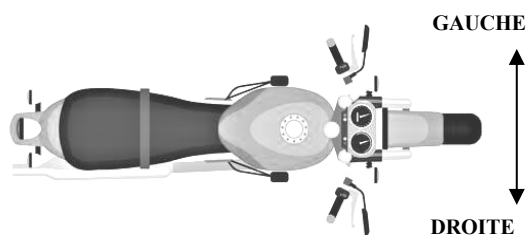
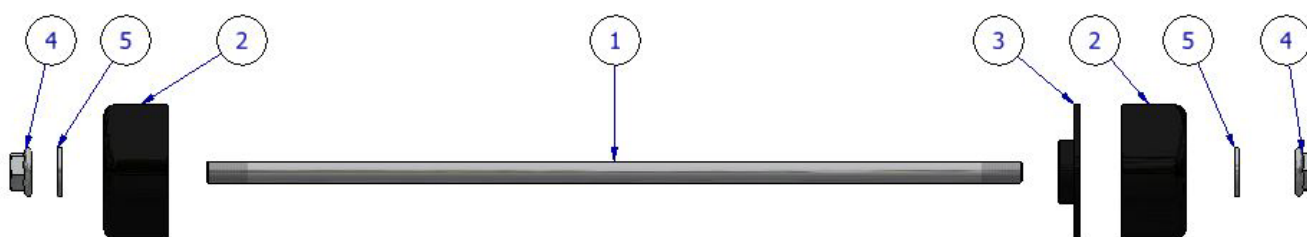

R&G Racing

Unit 1, Shelley's Lane, East Worldham, Alton, Hampshire, GU34 3AQ

Tel: +44 (0)1420 89007 Fax: +44 (0)1420 87301 www.rg-racing.com Email: info@rg-racing.com



NOTICE DE MONTAGE

- Faites glisser la barre d'axe (ARTICLE 1) à travers l'axe avant creuse jusqu'à ce que la partie filetée soit visible des deux côtés.
- Placer l'entretoise (ARTICLE 3) du côté droit de la barre d'axe (ARTICLE 1) et emboîter l'épaule de l'entretoise dans l'ouverture.
- Placez ensuite les protections (ARTICLE 2) sur la barre d'axe (ARTICLE 1) des deux côtés, en vous assurant que la partie filetée dépasse toujours des protections.
- Fixez les bobines (ARTICLE 2) avec les rondelles et les écrous (ARTICLE 4&5) des deux côtés. Serrez avec une douille de 13 mm des deux côtés, assurez-vous d'utiliser le RÉGLAGE GÉNÉRAL DU COUPLE à la page 2. Assurez-vous que les deux côtés ont une quantité égale d'engagement de filetage.

Utilisez le DIAGRAMME D'ASSEMBLAGE à la page deux pour un exemple de la façon dont il est assemblé.

Voir plus de produits R&G pour votre moto via ce lien :

ISSUE 1 – 19/05/2023 (JH)