



FITTING INSTRUCTIONS FOR LP0345
LICENCE PLATE BRACKET



THIS KIT CONTAINS THE ITEMS PICTURED AND LABELLED OVER PAGE.

SOME PARTS MAY BE SHOWN FOR CLARITY OF INSTRUCTIONS ONLY.

DO NOT PROCEED UNTIL YOU ARE SURE ALL PARTS ARE PRESENT.

PLEASE READ ALL INSTRUCTIONS BEFORE PROCEEDING.

**IF IN ANY DOUBT WHEN FITTING OUR PRODUCTS, CONSULT ONE OF OUR DEALERS
OR HAVE FITTED BY A QUALIFIED TECHNICIAN.**

PLEASE NOTE THAT THE WAY THE KIT IS PACKED DOES NOT NECESSARILY REPRESENT THE WAY OF
MOUNTING TO THE BIKE.

IN THE EVENT OF RUBBER WASHERS BEING USED TO HOLD COMPONENTS ONTO BOLTS,
THESE RUBBER WASHERS CAN BE THROWN AWAY.

DIGITAL COPIES OF THESE INSTRUCTIONS ARE AVAILABLE FROM:

WWW.RG-RACING.COM



<u>TOOLS REQUIRED</u>	<u>GENERAL TORQUE SETTINGS</u>
<ul style="list-style-type: none"> • T30 TORX TOOL • 6, 8, 12 & 13mm A/F SPANNERS • 3 & 4mm A/F ALLEN TOOL • 10mm A/F SOCKET AND WRENCH 	M4 BOLT = 8Nm M5 BOLT = 12Nm M6 BOLT = 15Nm M8 BOLT = 20Nm M10 BOLT = 40Nm M12 BOLT = 40Nm

LEGEND

ITEM NO.	DESCRIPTION	QTY
ITEM 1	LICENCE PLATE BRACKET (PART 1) FITTED WITH 4x S1266 SPACERS	1
ITEM 2	WIRING COVER (PART 2)	1
ITEM 3	LA0002 TAIL LIGHT WITH SHROUD	1
ITEM 4	M5x0.80x12.00mm COUNTERSUNK BOLT	6
ITEM 5	M5 WASHER	6
ITEM 6	M5x0.80 NYLOC NUT	6
ITEM 7	M6x1.00x25.00mm BUTTON HEAD BOLT	4
ITEM 8	M6 WASHER	8
ITEM 9	M6x1.00 NYLOC NUT	4
ITEM 10	M10x1.25 FLANGE NUT	2
ITEM 11	CON014 INDICATOR CONNECTOR	2
ITEM 12	CON026 NUMBER PLATE LIGHT CONNECTOR	1
ITEM 13	HEATSHRINK 150mm	6
ITEM 14	IWC0002 MINI INDICATOR WIRING COVER	2
ITEM 15	CT100BK CABLE TIES 100mm	8
ITEM 16	CLIP1 SELF-ADHESIVE CABLE CLIP	8
ITEM 17	RB50-20-00FG BLANKING GROMMET	2
ITEM 18	REFL3 REFLECTOR	1

R&G Racing

Unit 1, Shelley's Lane, East Worldham, Alton, Hampshire, GU34 3AQ

Tel: +44 (0)1420 89007 Fax: +44 (0)1420 87301 www.rg-racing.com Email: info@rg-racing.com



MAIN ASSEMBLY EXPLODED VIEW

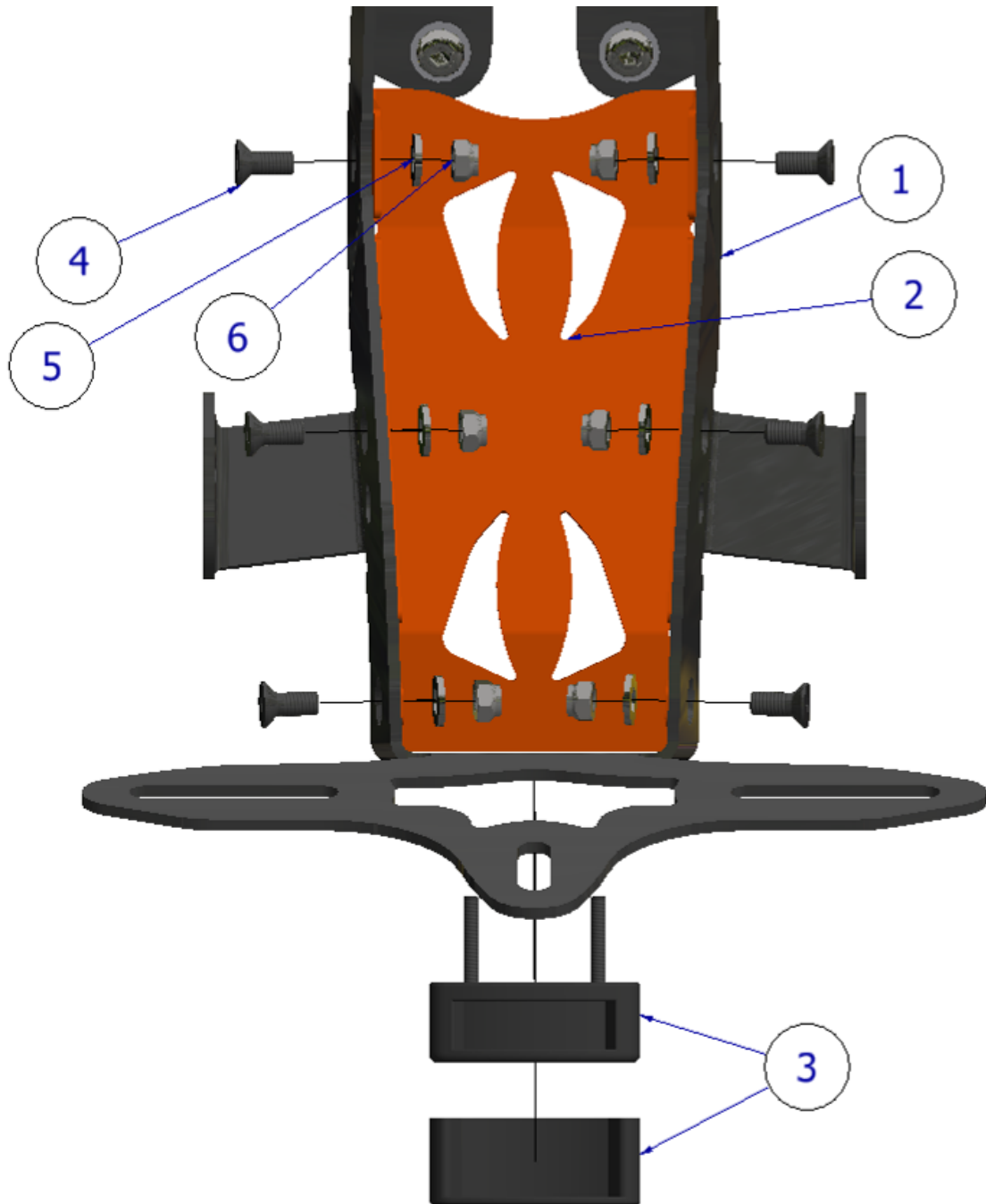



MOUNTING EXPLODED VIEW

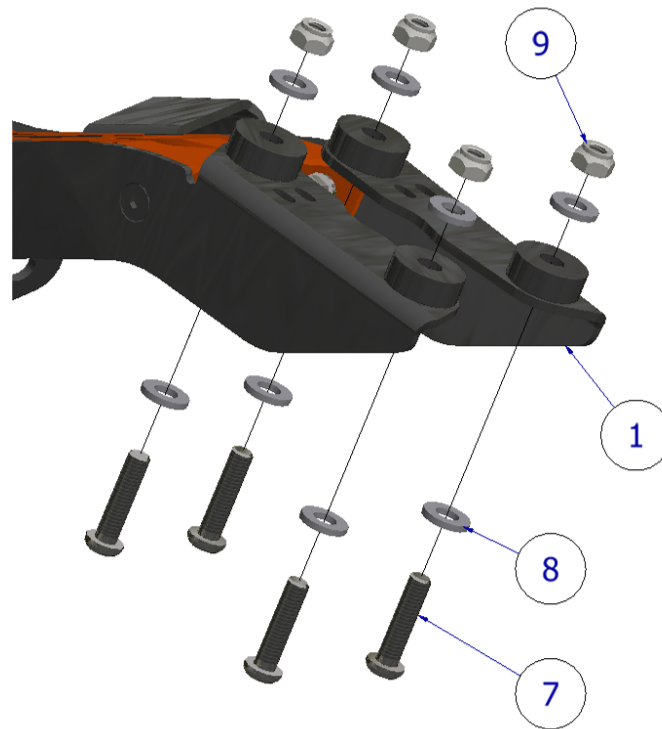

ADDITIONAL COMPONENTS

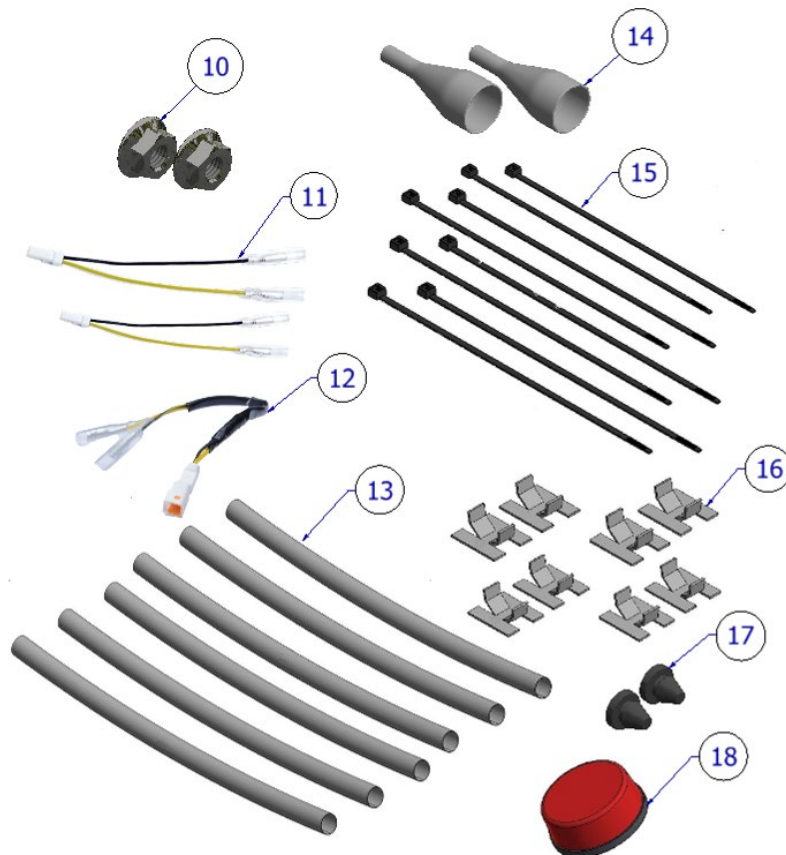



FITTING PICTURES



Picture 1

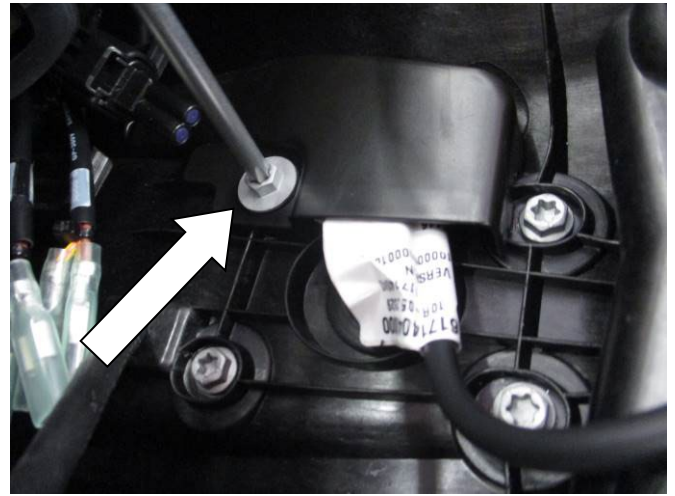

Picture 2

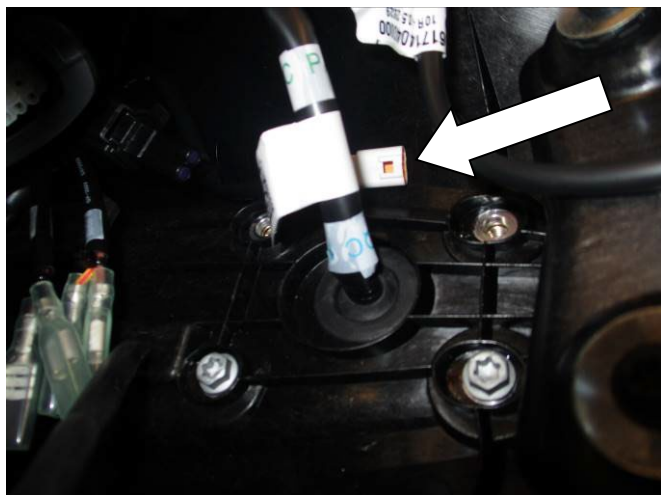

Picture 3



Picture 4



Picture 5



Picture 6



Picture 7

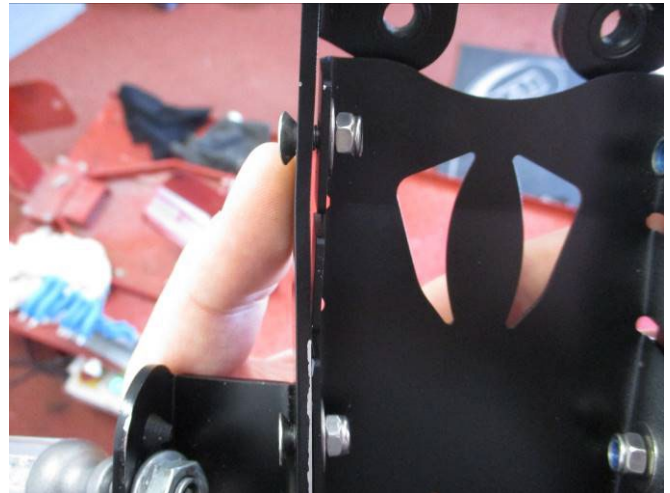

Picture 8



Picture 9



Picture 10



Picture 11



Picture 12



Picture 13



Picture 14

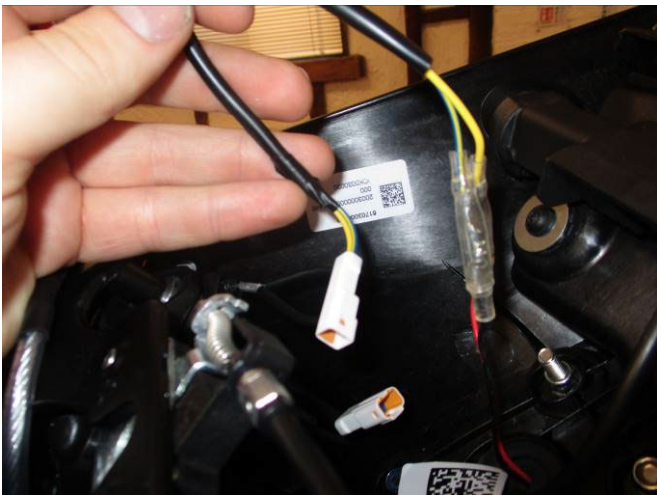

Picture 15

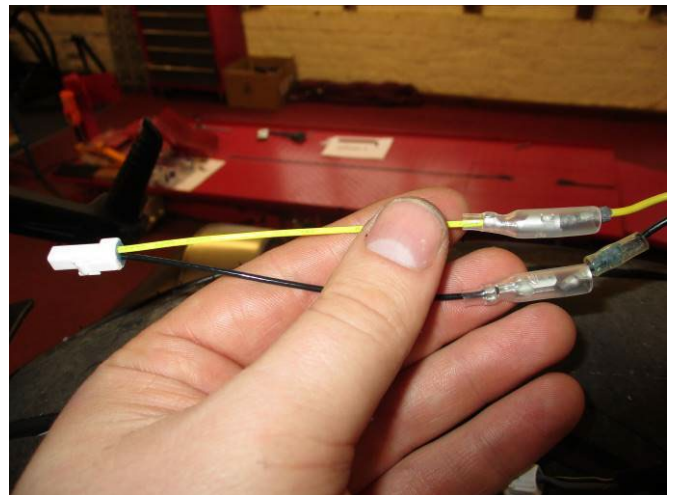

Picture 16

FITTING INSTRUCTIONS

- Begin by removing the passenger seat using the key, as shown in picture 1.
- Using a T30 Torx tool, remove the bolt shown in picture 2, then remove the wiring cover plate.
- Disconnect the tail bracket wiring connector shown in picture 3.
- While supporting the tail bracket, remove the remaining 3 T30 bolts, and pull the bracket away.
- Remove the pair of T30 bolts clamping the tail bracket together, as shown in picture 4, then gently separate the 2 halves, as shown in picture 5.
- Cut any securing cable ties and disconnect the 3 wiring connectors, then remove the sub-loom shown in picture 6.
- If using the original indicators, remove the mounting block with a 12mm spanner as shown in picture 7, then pull the indicator away.
- Slide the R&G wiring cover plate (**item 2**) up through the underside of the R&G tail bracket (**item 1**) so that the tapped holes on the cover plate line up with the countersink holes on the main bracket.
- Loosely fix the plate and bracket together using the 6x M5 countersunk bolts (**item 4**) as shown in picture 8, then slide an M5 washer (**item 5**) over the exposed end of each bolt and wind on a Nyloc nut (**item 6**). Use an 8mm spanner to hold the nuts while fully tightening the bolts with a 3mm Allen tool, as shown in picture 9.

R&G Racing

Unit 1, Shelley's Lane, East Worldham, Alton, Hampshire, GU34 3AQ

Tel: +44 (0)1420 89007 Fax: +44 (0)1420 87301 www.rg-racing.com Email: info@rg-racing.com



- Secure the R&G tail light (**item 3**) to the assembly using a 6mm spanner, then neatly wrap the wires with a length of heatshrink (**item 13**), as shown in picture 10.
- **If fitting R&G mini indicators** (R&G mini indicator product code RG371 for LED type, or RG372 for Aero Style LED type), secure to the R&G tail bracket using a 13mm spanner, then use the rubber bungs (**item 17**) to plug the locating holes, as shown in picture 11.
- **If refitting the KTM indicators**, secure to the R&G tail bracket using the included M10 nuts (item 10).
- Slide a wiring cover (**item 14**) over each nut, then neatly wrap the indicator wires with the included heatshrink (**item 13**) and push through the cut-outs on the tail bracket, as shown in picture 12.
- Tidy and secure the wiring to the tail bracket using the included cable ties (**item 15**) and cable clips (**item 16**), as outlined in picture 12.
- Slide an M6 washer (**item 8**) over each M6 bolt (**item 7**), then offer the tail bracket assembly up to the rear of the bike then push the wires through the rubber grommet, as shown in picture 13. Pass the bolts through the mounting holes, then slide an additional washer over the exposed ends so they sit in the mounting bores. Finally, wind an M6 Nyloc nut (**item 9**) onto each bolt, then fully tighten using a 4mm Allen tool, while holding the nuts with a 10mm socket, as shown in picture 14.
- Connect the tail light wiring adaptor (**item 12**) to the R&G tail light bullet connectors, as shown in picture 15, then connect to the sub-loom removed from the original bracket.
- If reusing the KTM indicators, simply reconnect them to the sub-loom.
- If using mini indicators, connect the indicator wiring adaptors (**item 11**) to the bullet connectors as shown in picture 16, then connect to the sub-loom.
- Reconnect the sub-loom to the main wiring loom, then use the remaining cable ties and clips to tidy the wiring within the tail of the bike.
- Refit passenger seat.
- Test operation of all lights.
- Mount the licence plate (it may require drilling) to the bracket in a central position.
- Depending on local laws, attach enclosed reflector (**item 18**) in an appropriate location.
- **IMPORTANT: IF FITTING A FULL-SIZE LICENCE PLATE AND PLACING IT FAR DOWN ON THE LICENCE PLATE HANGER, THERE IS A SMALL CHANCE OF THE LICENCE PLATE HITTING THE BACK WHEEL UNDER HEAVY LOAD AND OVER LARGE BUMPS IN THE ROAD. IT IS YOUR RESPONSIBILITY TO CHECK FOR THIS POSSIBILITY AND TAKE AVOIDING ACTION. FAILURE TO CHECK THIS COULD RESULT IN SERIOUS INJURY.**



ISSUE 1 - 22/09/2022 (DM)

CONSUMER NOTICE

The catalogue description and any exhibition of samples are only broad indications of the Products and R&G may make design changes which do not diminish their performance or visual appeal and supplying them in such state shall conform to the order. The Buyer acknowledges no representation or warranty (other than as to title) has been given or will apply to the Products other than those in R&G's order or confirmation and the Buyer confirms it has chosen the Products as being of merchantable quality and suitable for its particular purposes. Where R&G fits the Products or undertakes other services it shall exercise reasonable skill and care and rectify any fault free of charge unless the workmanship has been disturbed. The Buyer is responsible for ensuring that the warranty on the motorcycle is not affected by the fitting of the Products. On return of any defective Products R&G shall at its option either supply a replacement or refund the purchase money but shall not be liable if the Products have been modified or used or maintained otherwise than in accordance with R&G's or manufacturer's instructions and good engineering practice or if the defect arises from accident or neglect. Other than identified above and subject to R&G not limiting its liability for causing death and personal injury, it shall not be liable for indirect or consequential loss and otherwise its liability shall be limited to the amounts paid by the Buyer for the Products or the fitting or service concerned. These terms do not affect the Buyer's statutory rights.

R&G RACING RETURNS POLICY (NON-FAULTY GOODS)

Returns must be pre-authorized (if not pre-authorized the return will be rejected). Goods may only be returned direct to us if they were purchased direct from us (customer must prove if necessary). Otherwise to be returned to original vendor. Goods must be in re-sellable condition, in the opinion of R&G Racing. All returns are subject to a 25% restocking and handling fee (25% of the gross value exc. P&P - at the prevailing price at time of purchase). The customer must pay any and all carriage charges. No returns of discontinued products, unless within 14 days of purchase. This policy does not affect your statutory rights and does not refer to faulty goods.

R&G Racing

Unit 1, Shelley's Lane, East Worldham, Alton, Hampshire, GU34 3AQ

Tel: +44 (0)1420 89007 Fax: +44 (0)1420 87301 www.rg-racing.com Email: info@rg-racing.com



NOTICE DE MONTAGE POUR LP0345
SUPPORT DE PLAQUE



CE KIT CONTIENT LES ARTICLES ILLUSTRÉS ET ÉTIQUETÉS SUR LA PAGE.

CERTAINES PARTIES PEUVENT ÊTRE PRÉSENTES UNIQUEMENT POUR LA CLARTÉ DES INSTRUCTIONS.

NE PAS PROCÉDER AU MONTAGE TANT QUE VOUS N'ÊTES PAS SÛR QUE TOUTES LES PIÈCES SOIENT PRÉSENTES.

VEUILLEZ LIRE TOUTES LES INSTRUCTIONS AVANT DE CONTINUER.

EN CAS DE DOUTE LORS DU MONTAGE DE NOS PRODUITS, CONSULTEZ UN DE NOS REVENDUEURS OU FAITES APPEL À UN TECHNICIEN QUALIFIÉ.

VEUILLEZ NOTER QUE LA FAÇON DONT LE KIT EST EMBALLÉ NE REPRÉSENTE PAS NECESSAIREMENT LA MANIÈRE DE LE MONTER SUR LA MOTO.

SI DES RONDELLES EN CAOUTCHOUC SONT UTILISÉES POUR MAINTENIR LES COMPOSANTS SUR LES BOULONS, ELLES PEUVENT ÊTRE JETÉES.

NOTICE DISPONIBLE AU TÉLÉCHARGEMENT SUR : WWW.RG-RACING.COM



<u>OUTILS REQUIS</u>	<u>VALEURS DE SERRAGE RECOMMANDÉES</u>
<ul style="list-style-type: none"> • CLÉ TORX T30 • CLÉS À MOLETTE 6, 8, 12 & 13mm <ul style="list-style-type: none"> • CLÉ ALLEN 3 & 4mm • CLÉ À CLIQUET + DOUILLE 10mm 	M4 BOULON = 8Nm M5 BOULON = 12Nm M6 BOULON = 15Nm M8 BOULON = 20Nm M10 BOULON = 40Nm M12 BOULON = 40Nm

LÉGENDE

ARTICLE NO.	DESCRIPTION	QTÉ
ARTICLE 1	SUPPORT DE PLAQUE (PART 1) AVEC 4x ENTRETOISES S1266	1
ARTICLE 2	CACHE FIL (PART 2)	1
ARTICLE 3	LA0002 PROTECTION FEU DE PLAQUE	1
ARTICLE 4	M5x0.80x12.00mm BOULON	6
ARTICLE 5	M5 RONDELLE	6
ARTICLE 6	M5x0.80 ÉCROU	6
ARTICLE 7	M6x1.00x25.00mm BOULON	4
ARTICLE 8	M6 RONDELLE	8
ARTICLE 9	M6x1.00 ÉCROU	4
ARTICLE 10	M10x1.25 ÉCROU	2
ARTICLE 11	CON014 CONNECTEUR DE CLIGNOTANT	2
ARTICLE 12	CON026 CONNECTEUR DE FEU DE PLAQUE	1
ARTICLE 13	MANCHON THERMO RÉTRACTABLE 150mm	6
ARTICLE 14	IWC0002 CACHE FIL DE MINI CLIGNOTANT	2
ARTICLE 15	CT100BK COLLIERS DE SERRAGE 100mm	8
ARTICLE 16	CLIP1 CLIP AUTOCOLLANT	8
ARTICLE 17	RB50-20-00FG OEILLET D'OBTURATION	2
ARTICLE 18	REFL3 REFLECTEUR	1

R&G Racing

Unit 1, Shelley's Lane, East Worldham, Alton, Hampshire, GU34 3AQ

Tel: +44 (0)1420 89007 Fax: +44 (0)1420 87301 www.rg-racing.com Email: info@rg-racing.com



SCHÉMA D'ASSEMBLAGE PRINCIPAL





SCHÉMA DE MONTAGE



COMPOSANTS ADDITIONNELS

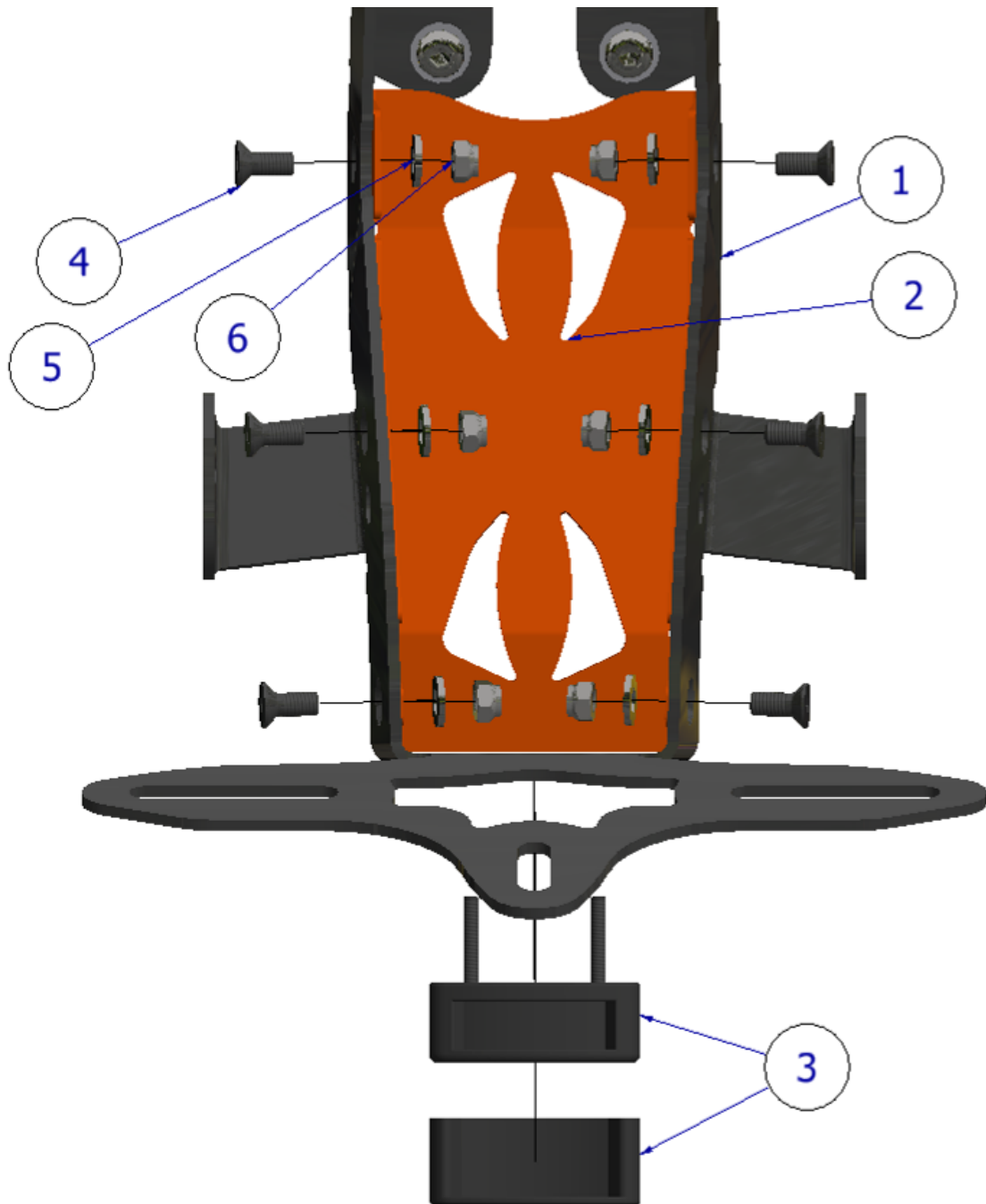
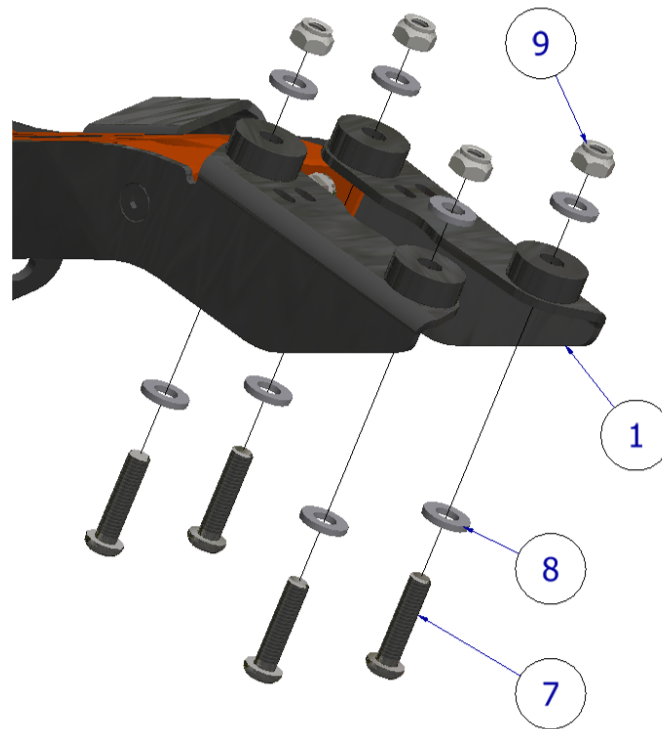
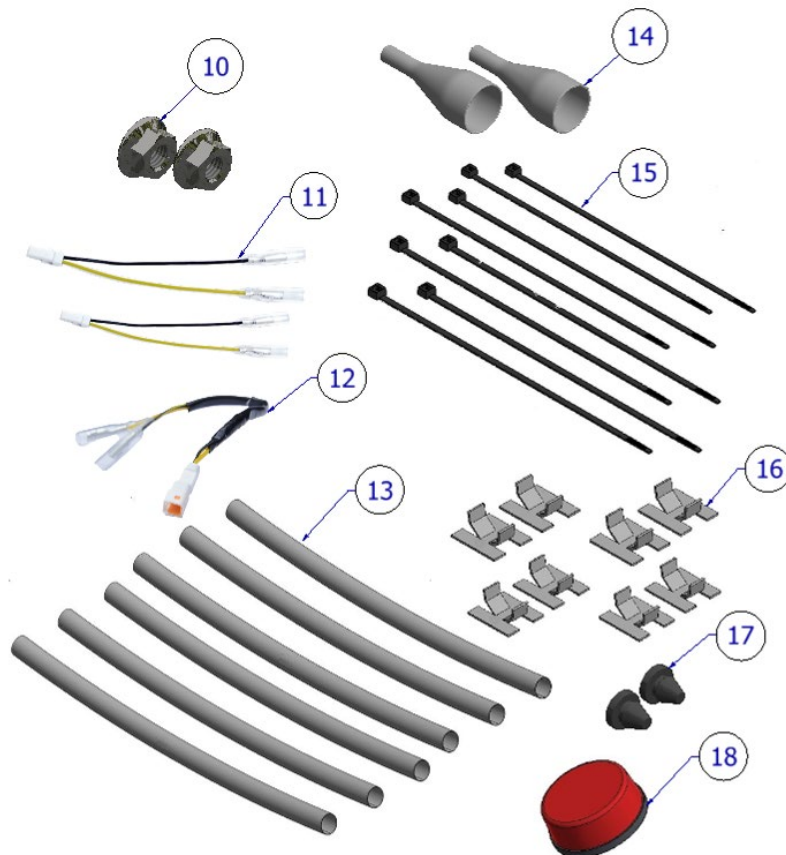



Photo 1

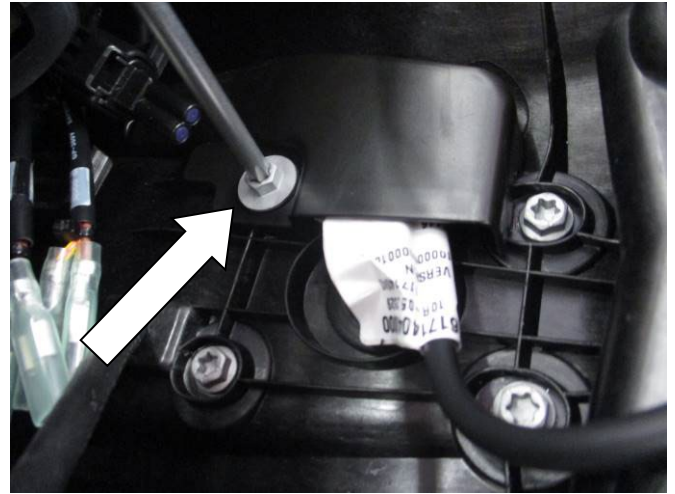

Photo 2

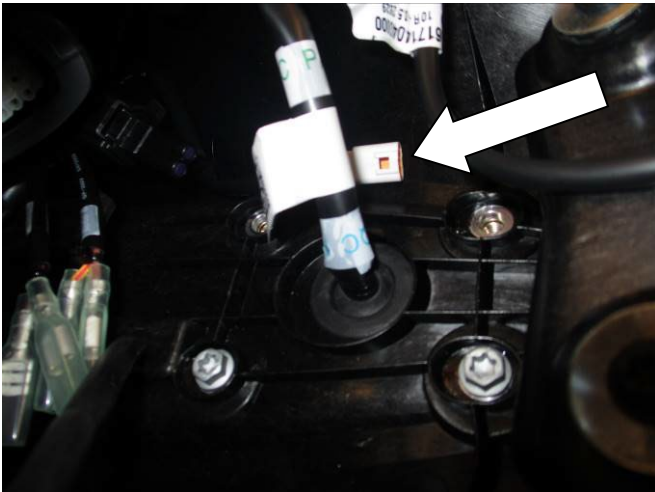

Photo 3



Photo 4



Photo 5



Photo 6



Photo 7

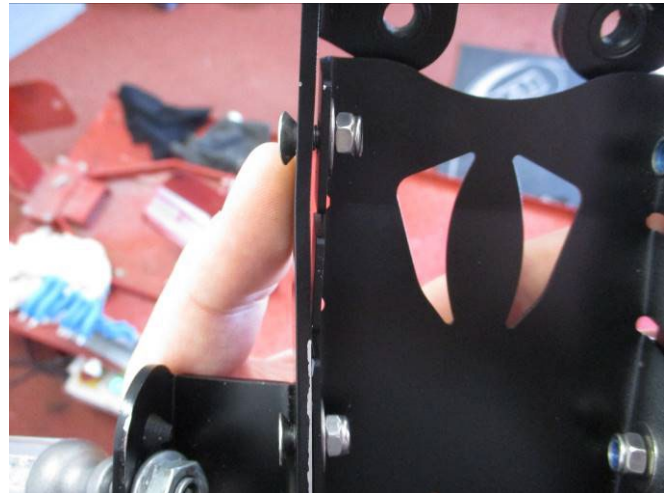

Photo 8



Photo 9



Photo 10



Photo 11

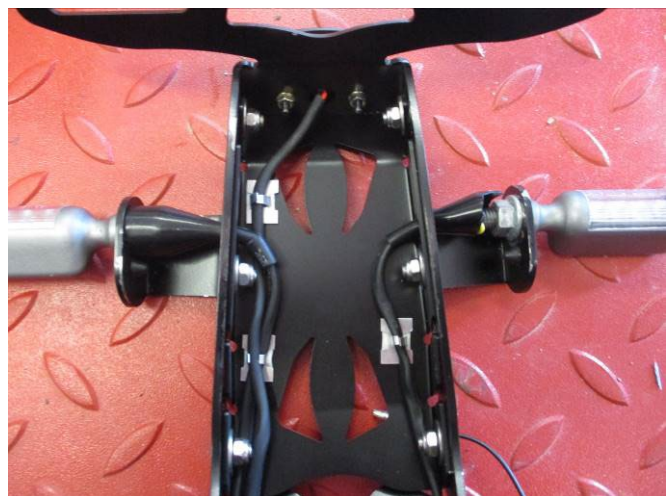

Photo 12



Photo 13



Photo 14

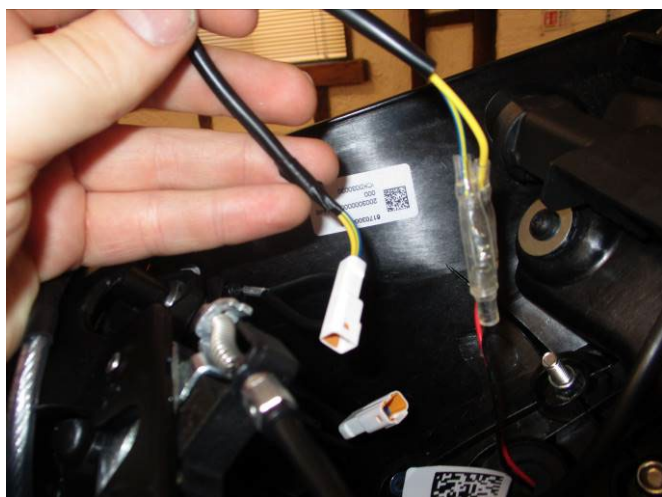

Photo 15

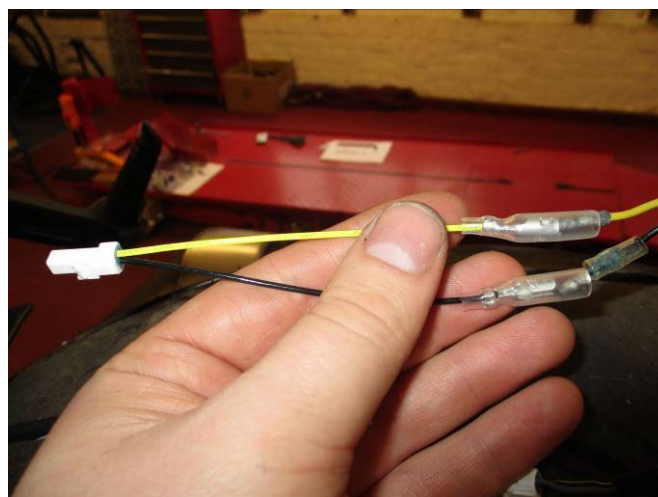

Photo 16

NOTICE DE MONTAGE

- Commencez par retirer le siège passager à l'aide de la clé, comme illustré sur la photo 1
- À l'aide d'une clé Torx T30, retirez le boulon illustré sur la photo 2, puis retirez la plaque de couverture du câblage.
- Débrancher le connecteur de câblage du support illustré sur la photo 3.
- Tout en soutenant le support, retirez les 3 boulons T30 restants et retirez le support.
- Retirez la paire de boulons T30 en serrant le support, comme indiqué sur la photo 4, puis séparez délicatement les 2 moitiés, comme indiqué sur la photo 5.
- Coupez les colliers de serrage puis déconnectez les 3 connecteurs de câblage, puis retirez le sous-faisceau illustré sur la photo 6.
- Si vous utilisez les clignotants d'origine, retirez le bloc de montage avec une clé de 12 mm comme indiqué sur la photo 7, puis retirez le clignotant.
- Faites glisser la plaque de recouvrement du câblage R&G (article 2) vers le haut à travers le dessous du support R&G (article 1) de sorte que les trous taraudés sur la plaque de couverture soient alignés avec les trous de fraisage sur le support principal.
- Fixez sans serrer la plaque et le support à l'aide des 6 boulons à tête fraisée M5 (article 4) comme indiqué sur la photo 8, puis faites glisser une rondelle M5 (article 5) sur l'extrémité exposée de

R&G Racing

Unit 1, Shelley's Lane, East Worldham, Alton, Hampshire, GU34 3AQ

Tel: +44 (0)1420 89007 Fax: +44 (0)1420 87301 www.rg-racing.com Email: info@rg-racing.com



chaque boulon et enroulez sur un écrou Nyloc (article 6). Utilisez une clé de 8 mm pour maintenir les écrous tout en serrant complètement les boulons avec un outil Allen de 3 mm, comme indiqué sur la photo 9.

- Fixez le support de feu R&G (article 3) sur l'ensemble à l'aide d'une clé de 6 mm, puis enveloppez soigneusement les fils avec une longueur de manchon thermorétractable (article 13), comme indiqué sur la photo 10.
- Si vous installez des mini-clignotants R&G (code produit mini-clignotant R&G RG371 pour le type LED ou RG372 pour le type Aero Style LED), fixez-le au support arrière R&G à l'aide d'une clé de 13 mm, puis utilisez les bouchons en caoutchouc (article 17) pour les placer dans les trous de fixation, comme indiqué sur la photo 11.
- Si vous remontez les clignotants KTM, fixez-les au support arrière R&G à l'aide des écrous M10 fournis (article 10).
- Glissez un cache fil (article 14) sur chaque écrou, puis enroulez soigneusement les fils de clignotants avec le manchon de protection inclus (article 13) et poussez le à travers les découpes du support, comme indiqué sur la photo 12.
- Tidy and secure the wiring to the tail bracket using the included cable ties (**article 15**) and cable clips (**article 16**), as outlined in photo 12.
- Slide an M6 washer (**article 8**) over each M6 boulon (**article 7**), then offer the tail bracket assembly up to the rear of the bike then push the wires through the rubber grommet, as shown in photo 13. Pass the boulons through the mounting holes, then slide an additional washer over the exposed ends so they sit in the mounting bores. Finally, wind an M6 Nyloc nut (**article 9**) onto each boulon, then fully tighten using a 4mm Allen tool, while holding the nuts with a 10mm socket, as shown in photo 14.
- Connect the tail light wiring adaptor (**article 12**) to the R&G tail light bullet connectors, as shown in photo 15, then connect to the sub-loom removed from the original bracket.
- If reusing the KTM indicators, simply reconnect them to the sub-loom.
- If using mini indicators, connect the indicator wiring adaptors (**article 11**) to the bullet connectors as shown in photo 16, then connect to the sub-loom.
- Reconnect the sub-loom to the main wiring loom, then use the remaining cable ties and clips to tidy the wiring within the tail of the bike.
- Ranger et fixer le câblage au support arrière à l'aide des attaches de câble (article 15) et des serre-câbles (article 16) fournis, comme indiqué sur la photo 12.
- Glissez une rondelle M6 (article 8) sur chaque boulon M6 (article 7), puis offrez le support de queue à l'arrière du vélo, puis poussez les fils à travers l'œillet en caoutchouc, comme indiqué sur la photo 13. Passez les boulons à travers les trous de montage, puis faites glisser une rondelle supplémentaire sur les extrémités exposées de sorte qu'elles reposent dans les trous de montage. Enfin, enroulez un écrou M6 Nyloc (article 9) sur chaque boulon, puis serrez à fond à l'aide d'un outil Allen de 4 mm, tout en maintenant les écrous avec une douille de 10 mm, comme indiqué sur la photo 14.
- Connectez l'adaptateur de câblage de feu arrière (article 12) aux connecteurs de balle de feu arrière R&G, comme illustré sur la photo 15, puis connectez-le au sous-métier retiré du support d'origine.
- Si vous réutilisez les indicateurs KTM, reconnectez-les simplement au sous-métier.
- Si vous utilisez des mini-indicateurs, connectez les adaptateurs de câblage d'indicateur (article 11) aux connecteurs de balle comme indiqué sur la photo 16, puis connectez-les au sous-métier.
- Rebranchez le sous-métier à tisser au faisceau de câbles principal, puis utilisez les attaches de câbles et les clips restants pour ranger le câblage dans la queue du vélo.
- Remontez le siège passager.
- Testez le fonctionnement de tous les feux.
- Montez la plaque d'immatriculation (elle peut nécessiter un perçage) sur le support en position centrale.
- Selon les lois locales, fixez le réflecteur fourni (article 18) à un endroit approprié.

R&G Racing

Unit 1, Shelley's Lane, East Worldham, Alton, Hampshire, GU34 3AQ

Tel: +44 (0)1420 89007 Fax: +44 (0)1420 87301 www.rg-racing.com Email: info@rg-racing.com



ISSUE 1 - 22/09/2022 (DM)

CONSUMER NOTICE

The catalogue description and any exhibition of samples are only broad indications of the Products and R&G may make design changes which do not diminish their performance or visual appeal and supplying them in such state shall conform to the order. The Buyer acknowledges no representation or warranty (other than as to title) has been given or will apply to the Products other than those in R&G's order or confirmation and the Buyer confirms it has chosen the Products as being of merchantable quality and suitable for its particular purposes. Where R&G fits the Products or undertakes other services it shall exercise reasonable skill and care and rectify any fault free of charge unless the workmanship has been disturbed. The Buyer is responsible for ensuring that the warranty on the motorcycle is not affected by the fitting of the Products. On return of any defective Products R&G shall at its option either supply a replacement or refund the purchase money but shall not be liable if the Products have been modified or used or maintained otherwise than in accordance with R&G's or manufacturer's instructions and good engineering practice or if the defect arises from accident or neglect. Other than identified above and subject to R&G not limiting its liability for causing death and personal injury, it shall not be liable for indirect or consequential loss and otherwise its liability shall be limited to the amounts paid by the Buyer for the Products or the fitting or service concerned. These terms do not affect the Buyer's statutory rights.

R&G RACING RETURNS POLICY (NON-FAULTY GOODS)

Returns must be pre-authorized (if not pre-authorized the return will be rejected). Goods may only be returned direct to us if they were purchased direct from us (customer must prove if necessary). Otherwise to be returned to original vendor. Goods must be in re-sellable condition, in the opinion of R&G Racing. All returns are subject to a 25% restocking and handling fee (25% of the gross value exc. P&P - at the prevailing price at time of purchase). The customer must pay any and all carriage charges. No returns of discontinued products, unless within 14 days of purchase. This policy does not affect your statutory rights and does not refer to faulty goods.

R&G Racing

Unit 1, Shelley's Lane, East Worldham, Alton, Hampshire, GU34 3AQ

Tel: +44 (0)1420 89007 Fax: +44 (0)1420 87301 www.rg-racing.com Email: info@rg-racing.com



MONTAGEANLEITUNG FÜR LP0345
KENNZEICHENHALTER



ALLE KIT-TEILE SIND UNTEN ABGEBILDET UND GEKENNZEICHNET.

DIE ABGEBILDETEN TEILE DIENEN LEDIGLICH ZUR ERKLÄRUNG.

ÜBERPRÜFEN SIE ZUERST, DASS ALLE TEILE VORHANDEN SIND.

LESEN SIE DIE MONTAGEANLEITUNG KOMPLETT DURCH, BEVOR SIE ANFANGEN.

**WENN SIE BEI DER MONTAGE DIESES PRODUKTES UNSICHER SIND, BITTE EINEN
UNSERER HÄNDLER KONTAKTIEREN ODER DAS KIT VON EINEM QUALIFIZIERTEN
ZWEIRAD-MECHANIKER MONTIEREN LASSEN.**

DIE VERPACKUNG DER TEILE STELLT NICHT DIE REIHENFOLGE DER MONTAGE DAR.

HINWEIS FÜR KITS MIT PLASTIKUNTERLEGSCHLEIBEN AN DEN SCHRAUBEN –

DIESE PLASTIK-UNTERLEGSCHLEIBEN WERDEN NICHT FÜR DEN EINBAU BENÖTIGT!

**EINE DIGITALE VERSION DIESER MONTAGEANLEITUNG KANN AUF
FOLGENDER SEITE HERUNTERGELADEN WERDEN:**

[WWW.RG-RACING.COM](http://www.rg-racing.com)

R&G Racing

Unit 1, Shelley's Lane, East Worldham, Alton, Hampshire, GU34 3AQ

Tel: +44 (0)1420 89007 Fax: +44 (0)1420 87301 www.rg-racing.com Email: info@rg-racing.com



<u>SIE BENÖTIGEN FOLGENDES WERKZEUG:</u>	<u>ALLGEM. ANZUGSDREHMOMENT:</u>
<ul style="list-style-type: none"> • T30 TORX-SCHLÜSSEL • 6, 8, 12 & 13mm SCHRAUBENSCHLÜSSEL <ul style="list-style-type: none"> • 3 & 4mm A/F INBUSSCHLÜSSEL • 10mm A/F STECKSCHLÜSSEL MIT VERLÄNGERUNG 	M4 SCHRAUBE = 8Nm M5 SCHRAUBE = 12Nm M6 SCHRAUBE = 15Nm M8 SCHRAUBE = 20Nm M10 SCHRAUBE = 40Nm M12 SCHRAUBE = 40Nm

LIEFERUMFANG

ARTIKEL NR.	BESCHREIBUNG	MENGE
ARTIKEL 1	KENNZEICHENHALTER (TEIL 1) MIT 4x S1266 DISTANZHALTER MONTIERT	1
ARTIKEL 2	ABDECKUNG FÜR KABEL (TEIL 2)	1
ARTIKEL 3	LA0002 KENNZEICHENBELEUCHTUNG MIT ABDECKUNG	1
ARTIKEL 4	M5x0,80x12.00mm SENKSCHRAUBE	6
ARTIKEL 5	M5 UNTERLEGSCHIEBE	6
ARTIKEL 6	M5x0,80 SELBSTSICHERNDE MUTTER	6
ARTIKEL 7	M6x1,00x25.00mm INBUSSCHRAUBE	4
ARTIKEL 8	M6 UNTERLEGSCHIEBE	8
ARTIKEL 9	M6x1,00 SELBSTSICHERNDE MUTTER	4
ARTIKEL 10	M10x1,25 FLANSCHMUTTER	2
ARTIKEL 11	CON014 VERBINDUNG BLINKER	2
ARTIKEL 12	CON026 VERBINDUNG KENNZEICHENBELEUCHTUNG	1
ARTIKEL 13	SCHRUMPFSCHLAUCH 150mm	6
ARTIKEL 14	IWC0002 MINIBLINKER KABEL-ABDECKUNG	2
ARTIKEL 15	CT100BK KABELBINDER 100mm	8
ARTIKEL 16	CLIP1 SELBSTKLEBENDE KABELCLIPS	8
ARTIKEL 17	RB50-20-00FG GUMMITÜLLE	2
ARTIKEL 18	REFL3 RÜCKSTRAHLER	1

R&G Racing

Unit 1, Shelley's Lane, East Worldham, Alton, Hampshire, GU34 3AQ

Tel: +44 (0)1420 89007 Fax: +44 (0)1420 87301 www.rg-racing.com Email: info@rg-racing.com



HAUPTZUSAMMENBAU - EXPLOSIONSZEICHNUNG

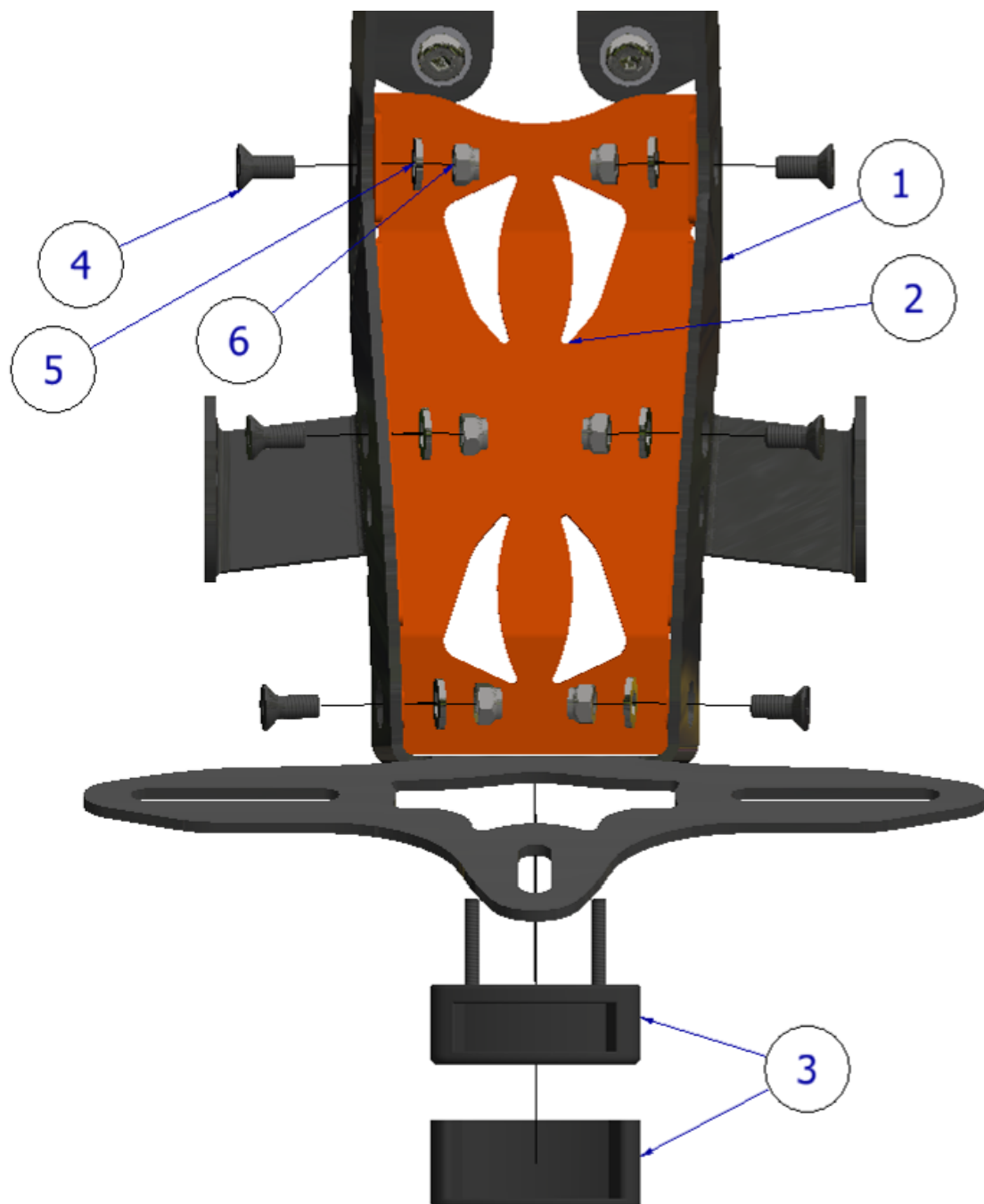



MONTAGE - EXPLOSIONSZEICHNUNG

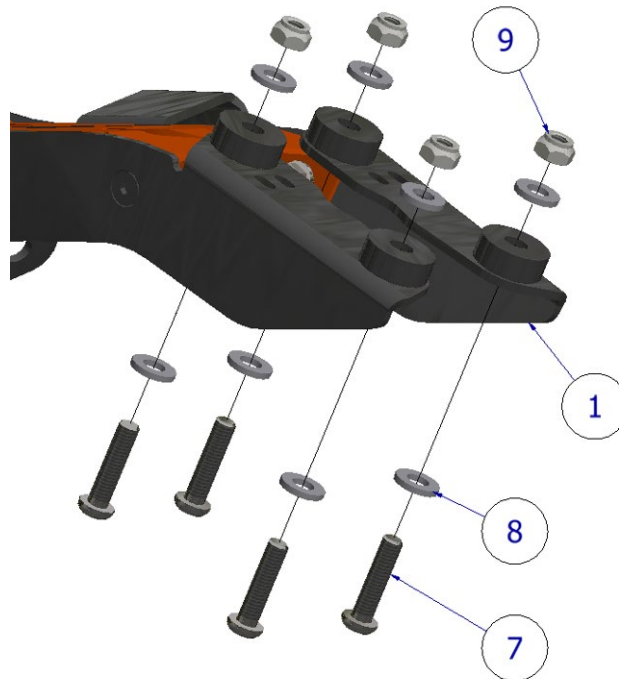



ZUSATZKOMPONENTE



Abbildung 1



Abbildung 2

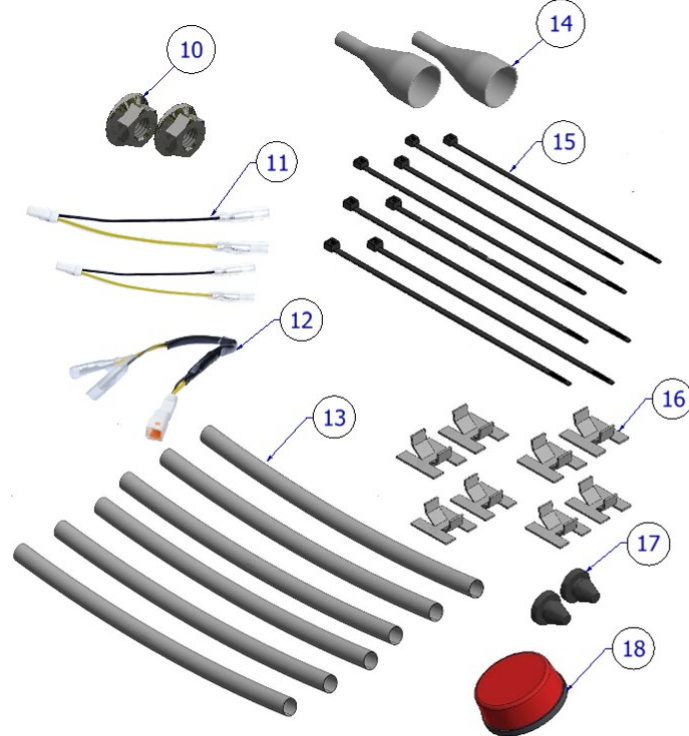

Abbildung 3



Abbildung 4

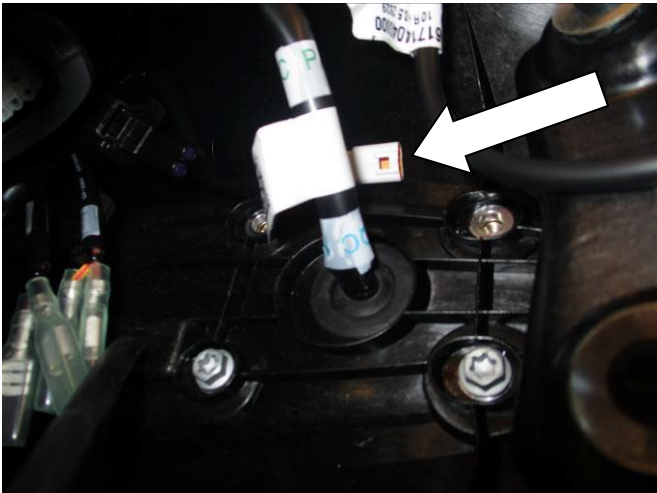

Abbildung 5



Abbildung 6



Abbildung 7



Abbildung 8



Abbildung 9



Abbildung 10



Abbildung 11

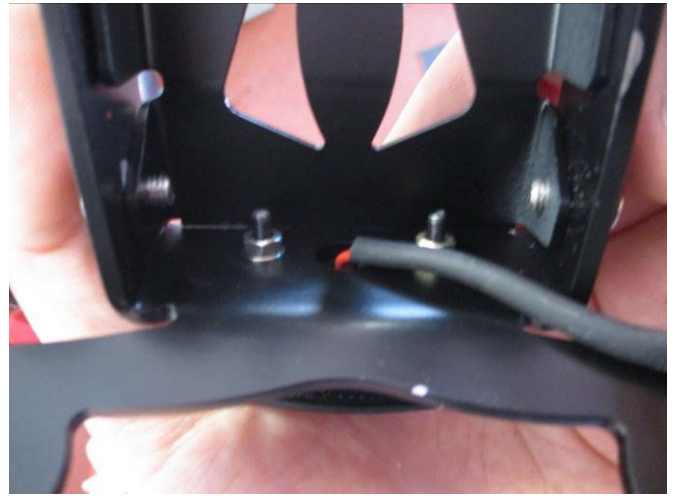

Abbildung 12



Abbildung 13



Abbildung 14



Abbildung 15



Abbildung 16

MONTAGEANLEITUNG

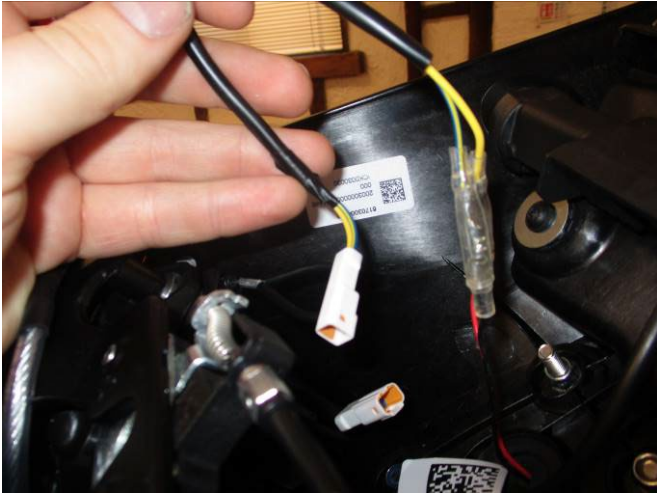
- Fangen Sie an, indem Sie den Beifahrersitz mit dem Schlüssel entriegeln und entfernen wie in Abbildung 1 abgebildet.
- Benutzen Sie einen T30 Torx-Schlüssel, um die Schraube zu entfernen, die in Abbildung 2 abgebildet ist, dann entfernen Sie die Abdeckplatte für die Kabel.
- Trennen Sie die Verbindung für die Kennzeichenbeleuchtung, die in Abbildung 3 abgebildet ist.
- Stützen Sie den Kennzeichenhalter während Sie die übrigen 3 x T30 Schrauben entfernen, dann ziehen Sie den Kennzeichenhalter weg vom Motorrad.
- Entfernen Sie die zwei T30 Schrauben, die den Kennzeichenhalter zusammenklemmen wie in Abbildung 4 abgebildet, dann teilen wie in Abbildung 5 abgebildet.
- Schneiden Sie jegliche Kabelbinder und trennen Sie die 3 Kabelverbinder – danach entfernen Sie den Kabelstrang wie in Abbildung 6 abgebildet.
- Wenn Sie die Originalblinker benutzen, entfernen Sie den Montageblock mit einem 12mm Schraubenschlüssel wie in Abbildung 7 abgebildet, dann ziehen Sie die Blinker weg.
- Schieben Sie die R&G Abdeckplatte für die Kabel (**Artikel 2**) hoch durch die Unterseite des R&G Kennzeichenhalters (**Artikel 1**), so dass die Gewindebohrungen an der Abdeckplatte mit den Senkbohrungen am Haupthalter ausgerichtet sind.
- Die Platte und den Kennzeichenhalter mit den 6x M5 Senkschrauben (**Artikel 4**) lose zusammen fixieren wie in Abbildung 8 abgebildet, dann eine M5 Unterlegscheibe (**Artikel 5**) über das hervorstehende Ende jeder Schraube schieben und eine selbstsichernde Mutter (**Artikel 6**) anbringen. Benutzen Sie einen 8mm Schraubenschlüssel, um die Mutter zu halten während Sie die Schrauben mit einem 3mm Inbusschlüssel festziehen wie in Abbildung 9 abgebildet.
- Sichern Sie die R&G Kennzeichenbeleuchtung (**Artikel 3**) an der Einheit mit einem 6mm Schraubenschlüssel, dann die Kabel im Schrumpfschlauch einwickeln (**Artikel 13**) wie in Abbildung 10 abgebildet.
- **Wenn Sie R&G Miniblinker montieren** (R&G Miniblinker Artikel-Nr. RG371 für LED oder RG372 für Aero LED): Befestigen Sie sie am R&G Kennzeichenhalter mit einem 13mm Schraubenschlüssel. Die Gummitüllen (**Artikel 17**) anschließend in die Aufnahmebohrung einsetzen wie in Abbildung 11 abgebildet.
- **Wenn Sie die KTM Blinker wieder montieren:** Diese mit den mitgelieferten M10 Muttern (**Artikel 10**) am R&G Kennzeichenhalter befestigen.
- Eine Kabelabdeckung (**Artikel 14**) an jeder Mutter anbringen, dann die Kabel für die Blinker ordentlich mit dem Schrumpfschlauch vom Kit (**Artikel 13**) umwickeln und durch die Ausschnitte im Kennzeichenhalter schieben wie in Abbildung 12 abgebildet.
- Die Kabel sicher und ordentlich mit den mitgelieferten Kabelbinder (**Artikel 15**) und Kabelclips (**Artikel 16**) am Kennzeichenhalter befestigen wie in Abbildung 12 dargestellt.

R&G Racing

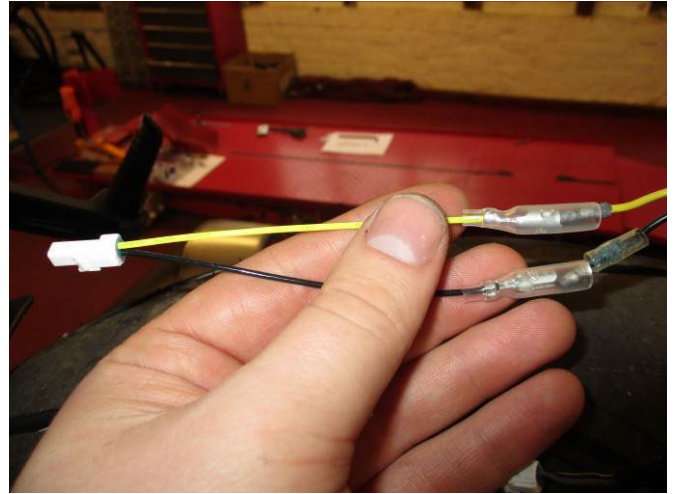
Unit 1, Shelley's Lane, East Worldham, Alton, Hampshire, GU34 3AQ

Tel: +44 (0)1420 89007 Fax: +44 (0)1420 87301 www.rg-racing.com Email: info@rg-racing.com



- Eine M6 Unterlegscheibe (**Artikel 8**) an jeder M6 Schraube (**Artikel 7**) anbringen und die Kennzeichenhalter-Einheit an das Heck des Motorrades ansetzen. Die Kabel durch die Gummitülle schieben wie in Abbildung 13 abgebildet. Die Schrauben in die Montageöffnungen einsetzen, dann die zusätzlichen Unterlegscheiben an den hervorstehenden Enden anbringen, so dass sie in den Montagebohrungen passen. Anschließend eine M6 selbstsichernde Mutter (**Artikel 9**) an jeder Schraube anbringen und mit einem 4mm Inbusschlüssel festziehen, während Sie die Muttern mit einem 10mm Steckschlüssel halten wie in Abbildung 14 abgebildet.
- Verbinden Sie den Adapter für die Kennzeichenbeleuchtung (**Artikel 12**) mit den R&G Verbindungen für die Kennzeichenbeleuchtung wie in Abbildung 15 abgebildet. Dann mit dem Kabelstrang, der zuvor vom original Kennzeichenhalter entfernt wurde, verbinden.
- Wenn Sie die KTM-Blinker wiederverwenden, diese einfach wieder mit dem Kabelstrang verbinden.
- Wenn Sie Miniblinker benutzen, verbinden Sie die Kabel-Adapter für die Blinker (**Artikel 11**) mit den Verbindungen wie in Abbildung 16 abgebildet, dann mit dem Kabelstrang verbinden.
- Den Kabelstrang wieder mit dem Hauptkabelbaum verbinden und die übrigen Kabelbinder und Clips benutzen, um die Kabel innerhalb des Motorrades ordentlich zu verstauen.
- Montieren Sie den Beifahrersitz wie ursprünglich wieder.
- Überprüfen Sie die Funktion der Beleuchtung.
- Montieren Sie das amtliche Kennzeichen (Bohrungen im Kennzeichen evtl. notwendig) mittig am Kennzeichenhalter.
- Entsprechend der gesetzlichen Vorschriften, den mitgelieferten Rückstrahler (**Artikel 18**) an die dafür vorgesehene Stelle anbringen.

AUSGABE 1 – 22/09/2022 (DM)

CONSUMER NOTICE

The catalogue description and any exhibition of samples are only broad indications of the Products and R&G may make design changes which do not diminish their performance or visual appeal and supplying them in such state shall conform to the order. The Buyer acknowledges no representation or warranty (other than as to title) has been given or will apply to the Products other than those in R&G's order or confirmation and the Buyer confirms it has chosen the Products as being of merchantable quality and suitable for its particular purposes. Where R&G fits the Products or undertakes other services it shall exercise reasonable skill and care and rectify any fault free of charge unless the workmanship has been disturbed. The Buyer is responsible for ensuring that the warranty on the motorcycle is not affected by the fitting of the Products. On return of any defective Products R&G shall at its option either supply a replacement or refund the purchase money but shall not be liable if the Products have been modified or used or maintained otherwise than in accordance with R&G's or manufacturer's instructions and good engineering practice or if the defect arises from accident or neglect. Other than identified above and subject to R&G not limiting its liability for causing death and personal injury, it shall not be liable for indirect or consequential loss and otherwise its liability shall be limited to the amounts paid by the Buyer for the Products or the fitting or service concerned. These terms do not affect the Buyer's statutory rights.

R&G RACING RETURNS POLICY (NON-FAULTY GOODS)

Returns must be pre-authorized (if not pre-authorized the return will be rejected). Goods may only be returned direct to us if they were purchased direct from us (customer must prove if necessary). Otherwise to be returned to original vendor. Goods must be in re-sellable condition, in the opinion of R&G Racing. All returns are subject to a 25% restocking and handling fee (25% of the gross value exc. P&P – at the prevailing price at time of purchase). The customer must pay any and all carriage charges. No returns of discontinued products, unless within 14 days of purchase. This policy does not affect your statutory rights and does not refer to faulty goods.

R&G Racing

Unit 1, Shelley's Lane, East Worldham, Alton, Hampshire, GU34 3AQ

Tel: +44 (0)1420 89007 Fax: +44 (0)1420 87301 www.rg-racing.com Email: info@rg-racing.com