



## **FITTING INSTRUCTIONS FOR UNIVERSAL LOCKSTOP SAVERS**



**This kit contains the items pictured and labelled over the page.**

**Some parts may be shown for clarity of instructions only.**

**Do not proceed until you are sure all parts are present.**

**Please read all instructions before proceeding.**

**IF IN ANY DOUBT WHEN FITTING OUR PRODUCTS, CONSULT ONE OF OUR DEALERS  
OR HAVE THE KIT FITTED BY A QUALIFIED TECHNICIAN.**

Please note that the way the kit is packed does not necessarily represent the way of mounting to the bike.

In the event of rubber washers being used to hold components onto bolts, these rubber washers can be thrown away.

**DIGITAL COPIES OF THESE INSTRUCTIONS ARE AVAILABLE FROM**

[www.rg-racing.com](http://www.rg-racing.com)

R&G

Unit 1, Shelley's Lane, East Worldham, Alton, Hampshire, GU34 3AQ

Tel: +44 (0)1420 89007 Fax: +44 (0)1420 87301 [www.rg-racing.com](http://www.rg-racing.com) Email: [info@rg-racing.com](mailto:info@rg-racing.com)



**LEGEND**

ITEM No.	DESCRIPTION	QTY
ITEM 1	JUBILEE CLAMP (45MM-60MM DIAMETER)	2
ITEM 2	LOCKSTOP SAVER BUMP STOP (SIZE MAY VARY)	2
ITEM 3	PROTECTIVE RUBBER EXTRUSION	2

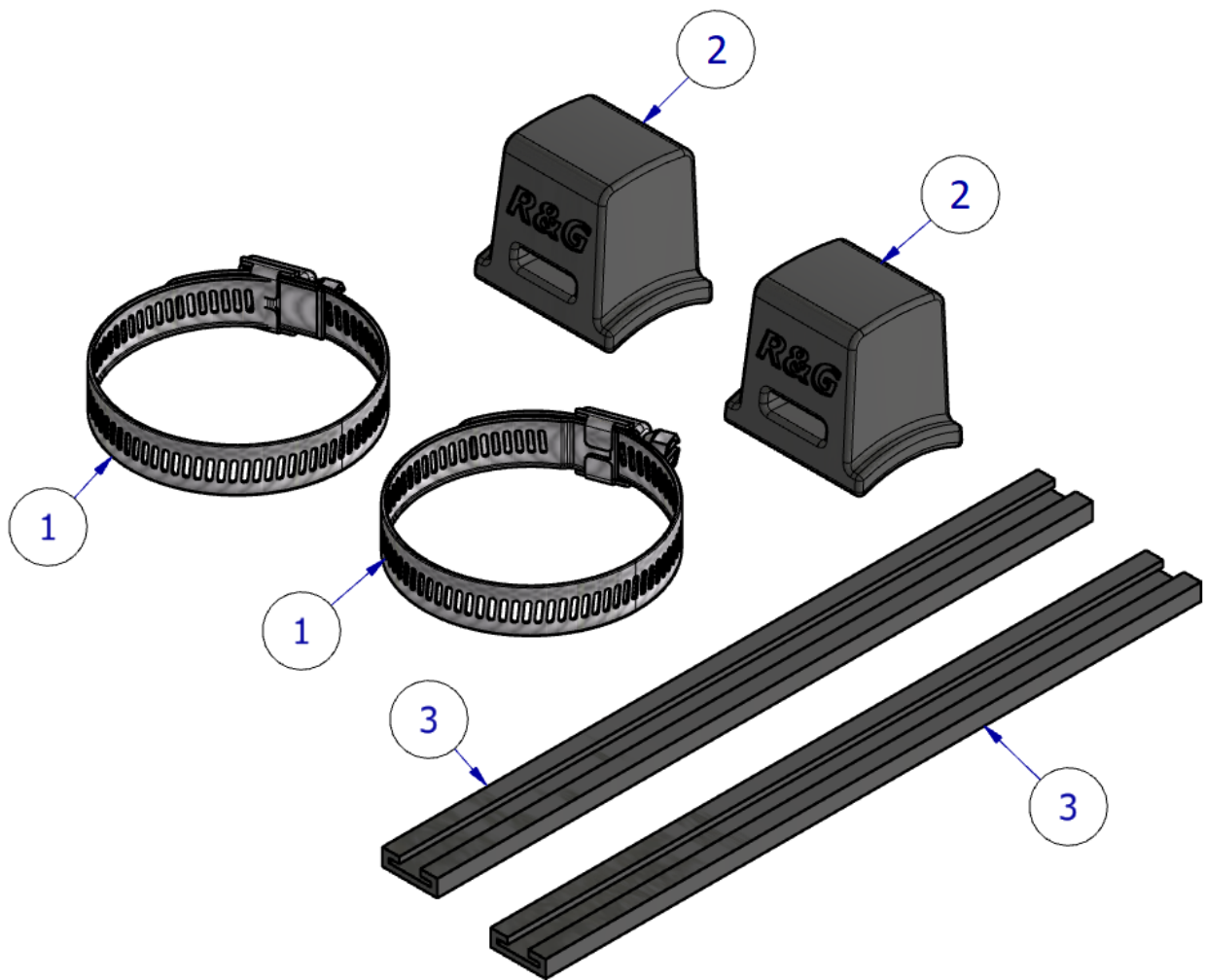

R&G

Unit 1, Shelley's Lane, East Worldham, Alton, Hampshire, GU34 3AQ

Tel: +44 (0)1420 89007 Fax: +44 (0)1420 87301 [www.rg-racing.com](http://www.rg-racing.com) Email: [info@rg-racing.com](mailto:info@rg-racing.com)



Picture 1



Picture 2

### **FITTING INSTRUCTIONS**

The R&G Lockstop Saver is designed to be installed onto both upper front suspension fork legs in the headstock area and is intended to help to prevent damage to the metal steering lockstop in the event of significant instability or an accident. Please note that this kit also reduces total lock-to-lock travel and so prevents the use of the keyed steering lock. Please follow the installation instructions carefully. Intended for Track Use Only.

- To fit the Lockstop savers, wrap one of the rubber extrusions (item 3) around the fork leg in an appropriate position (as detailed below), mark the extrusion and cut approximately 35mm shorter than this mark.



- Thread one of the bump stops (**item 2**) onto one of the jubilee clips (**item 1**)
- Thread one of the cut rubber extrusions (**item 3**) onto the jubilee clip.
- Offer this assembly into an appropriate position by wrapping the jubilee clip around the fork and rotating the bump stop as shown in pictures 1 & 2, using the guide below to select the correct position.

R&G

Unit 1, Shelley's Lane, East Worldham, Alton, Hampshire, GU34 3AQ

Tel: +44 (0)1420 89007 Fax: +44 (0)1420 87301 [www.rg-racing.com](http://www.rg-racing.com) Email: [info@rg-racing.com](mailto:info@rg-racing.com)



### **Selecting the correct position for the Lockstop Saver**

You may have several options for fitment depending on the model of your motorcycle—**it is your responsibility to ensure this product is fitted safely and is checked on a regular basis.** The Lockstop saver should be positioned in a location where the bump stop will be slightly compressed between the motorcycle fork and the frame when the handlebars are turned to full lock in either direction.

#### **It is important to ensure that:**

- Both bump stops are in the same position side-to side.
- Bump stop should not contact the fuel tank or bodywork.
- Bump stop does not catch/trap any cabling/hoses/wiring when in operation (at full lock in both directions).
- Engage the jubilee clip and tighten into position using a 7mm spanner or socket. The rubber extrusion should compress slightly. Overtightening could lead to damage to the motorcycle fork.
- Repeat the above for the opposite fork.
- **Test steering action before riding. It is your responsibility to check the above instructions have been followed and take avoiding action where necessary. Failure to check this could result in serious injury or damage to the motorcycle.**

ISSUE 2 – 17/10/2023 (DM)

#### **CONSUMER NOTICE**

The catalogue description and any exhibition of samples are only broad indications of the Products and R&G may make design changes which do not diminish their performance or visual appeal and supplying them in such state shall conform to the order. The Buyer acknowledges no representation or warranty (other than as to title) has been given or will apply to the Products other than those in R&G's order or confirmation and the Buyer confirms it has chosen the Products as being of merchantable quality and suitable for its particular purposes. Where R&G fits the Products or undertakes other services it shall exercise reasonable skill and care and rectify any fault free of charge unless the workmanship has been disturbed. The Buyer is responsible for ensuring that the warranty on the motorcycle is not affected by the fitting of the Products. On return of any defective Products R&G shall at its option either supply a replacement or refund the purchase money but shall not be liable if the Products have been modified or used or maintained otherwise than in accordance with R&G's or manufacturer's instructions and good engineering practice or if the defect arises from accident or neglect. Other than identified above and subject to R&G not limiting its liability for causing death and personal injury, it shall not be liable for indirect or consequential loss and otherwise its liability shall be limited to the amounts paid by the Buyer for the Products or the fitting or service concerned. These terms do not affect the Buyer's statutory rights.

#### **R&G RETURNS POLICY (NON-FAULTY GOODS)**

Returns must be pre-authorized (if not pre-authorized the return will be rejected). Goods may only be returned direct to us if they were purchased direct from us (customer must prove if necessary). Otherwise to be returned to original vendor. Goods must be in re-sellable condition, in the opinion of R&G Racing. All returns are subject to a 25% restocking and handling fee (25% of the gross value exc. P&P – at the prevailing price at time of purchase). The customer must pay any and all carriage charges. No returns of discontinued products, unless within 14 days of purchase. This policy does not affect your statutory rights and does not refer to faulty goods.

R&G

Unit 1, Shelley's Lane, East Worldham, Alton, Hampshire, GU34 3AQ

Tel: +44 (0)1420 89007 Fax: +44 (0)1420 87301 [www.rg-racing.com](http://www.rg-racing.com) Email: [info@rg-racing.com](mailto:info@rg-racing.com)