

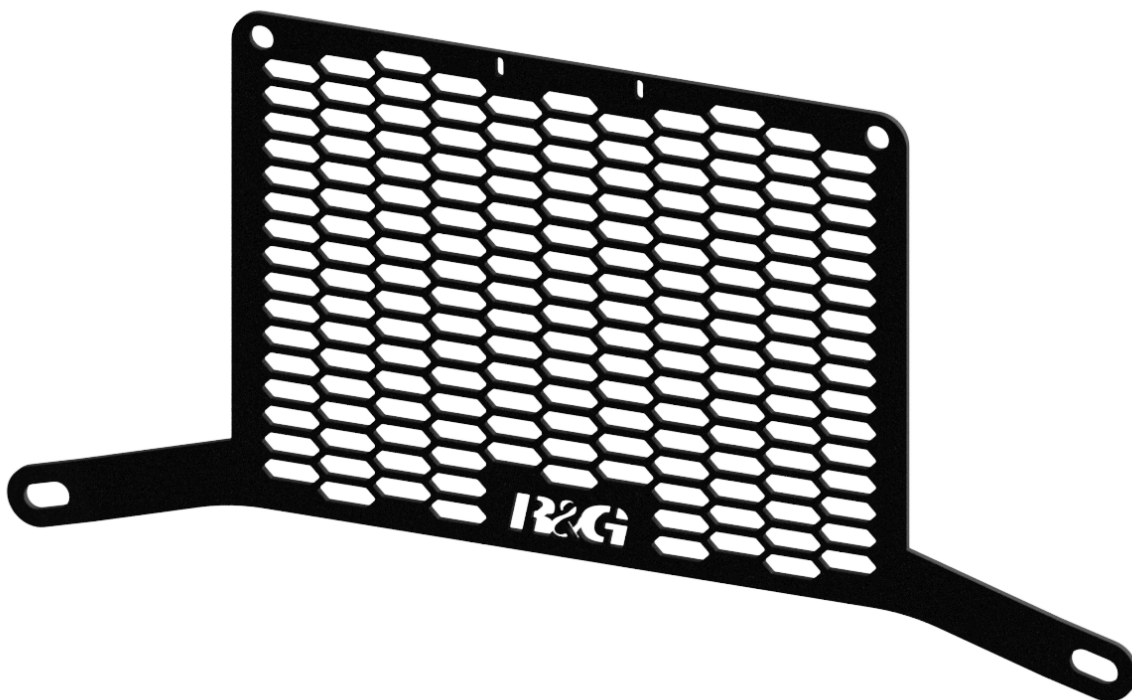

FITTING INSTRUCTIONS FOR OCG0051PRO
OIL COOLER GUARD



THIS KIT CONTAINS THE ITEMS PICTURED AND LABELLED OVER PAGE.

SOME PARTS MAY BE SHOWN FOR CLARITY OF INSTRUCTIONS ONLY.

DO NOT PROCEED UNTIL YOU ARE SURE ALL PARTS ARE PRESENT.

PLEASE READ ALL INSTRUCTIONS BEFORE PROCEEDING.

**IF IN ANY DOUBT WHEN FITTING OUR PRODUCTS, CONSULT ONE OF OUR DEALERS
OR HAVE FITTED BY A QUALIFIED TECHNICIAN.**

PLEASE NOTE THAT THE WAY THE KIT IS PACKED DOES NOT NECESSARILY REPRESENT THE WAY OF
MOUNTING TO THE BIKE.

IN THE EVENT OF RUBBER WASHERS BEING USED TO HOLD COMPONENTS ONTO BOLTS,
THESE RUBBER WASHERS CAN BE THROWN AWAY.

DIGITAL COPIES OF THESE INSTRUCTIONS ARE AVAILABLE FROM:

WWW.RG-RACING.COM



<u>TOOLS REQUIRED</u>	<u>GENERAL TORQUE SETTINGS</u>
<ul style="list-style-type: none"> • SET OF ALLEN KEYS TO INCLUDE 4mm. <ul style="list-style-type: none"> • NEEDLE NOSE PLIERS. • CABLE CUTTERS OR SCISSORS. 	<p>M4 BOLT = 8Nm M5 BOLT = 12Nm M6 BOLT = 15Nm M8 BOLT = 20Nm M10 BOLT = 40Nm M12 BOLT = 40Nm</p>

LEGEND

ITEM NO.	DESCRIPTION	QTY
ITEM 1	OCG0051 OIL COOLER GUARD	1
ITEM 2	S1387 OIL COOLER GUARD SPACER	2
ITEM 3	M6X 65MM BUTTON HEAD BOLT	2
ITEM 4	M6x12MM O/D WASHER	2
ITEM 5	CT220 CABLE TIE	2
ITEM 6	RUBBER BUNG (RB0015)	4

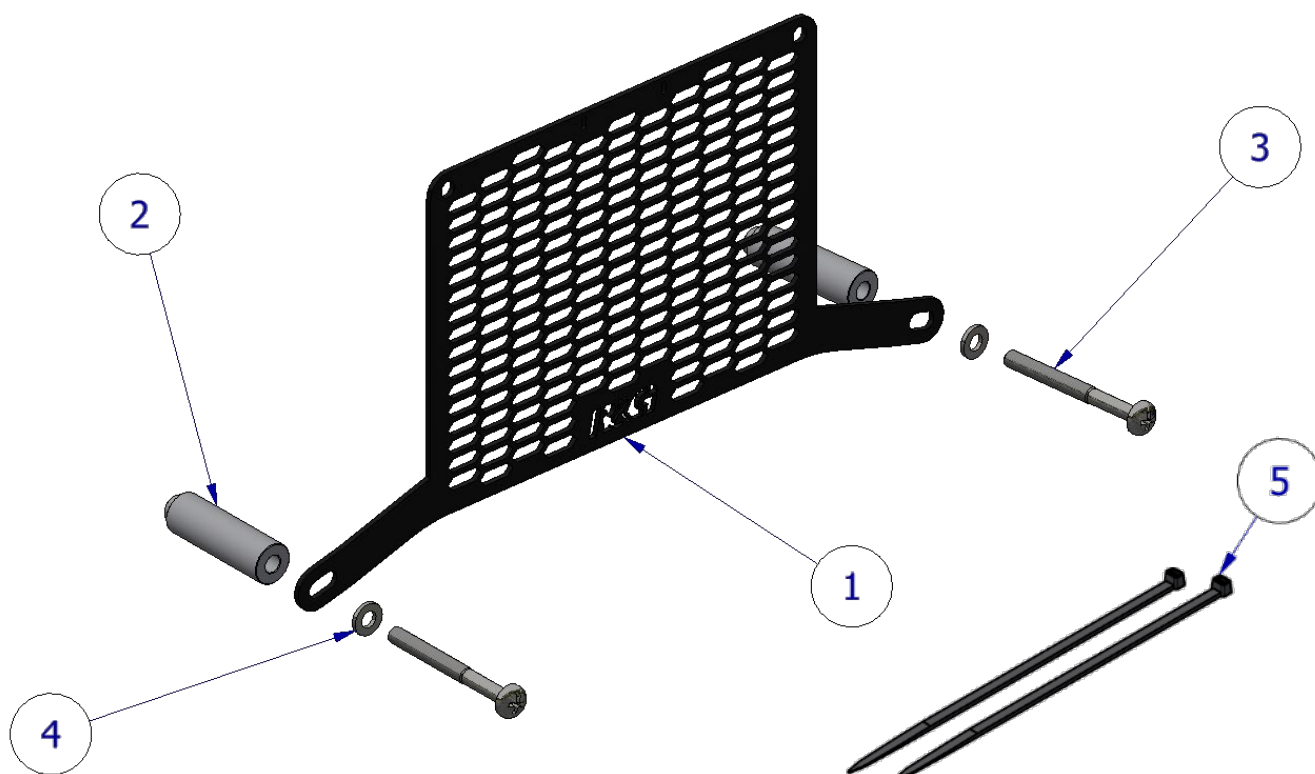

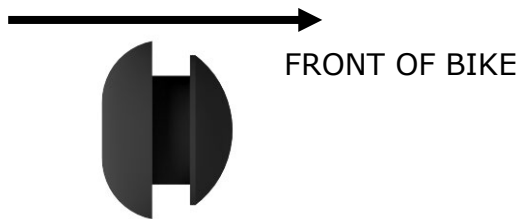
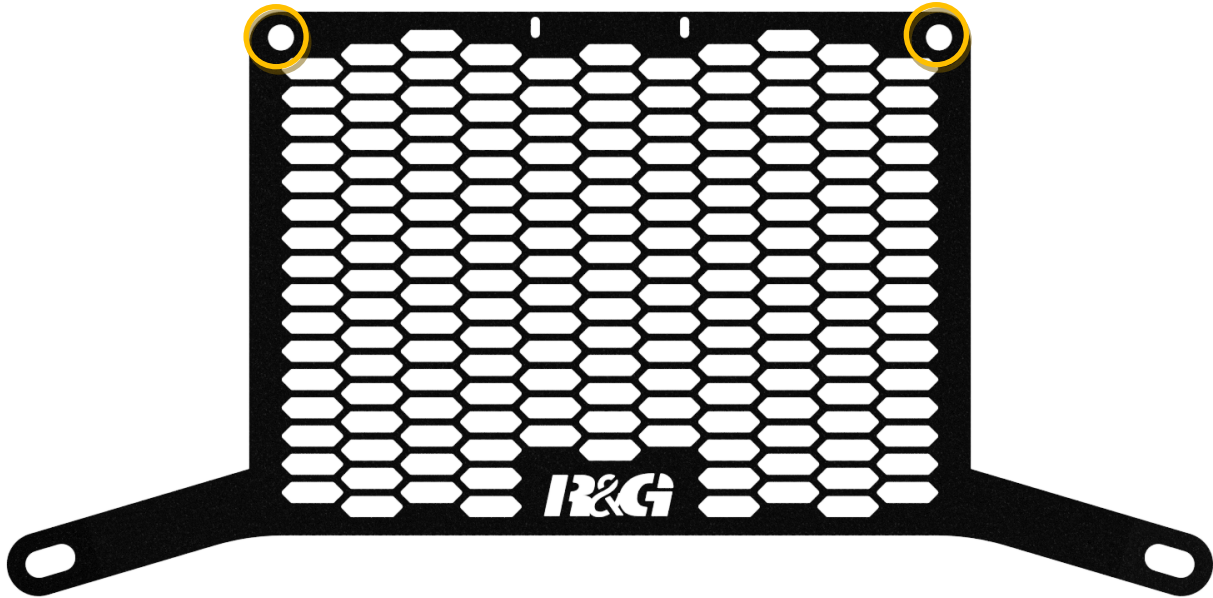

FITTING PICTURES

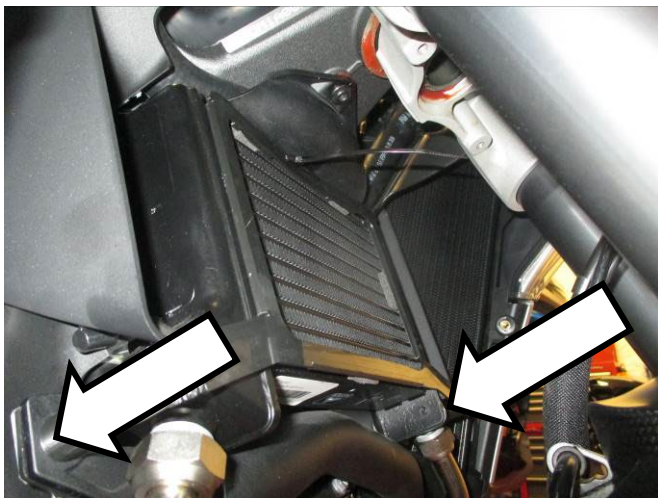

Picture 1

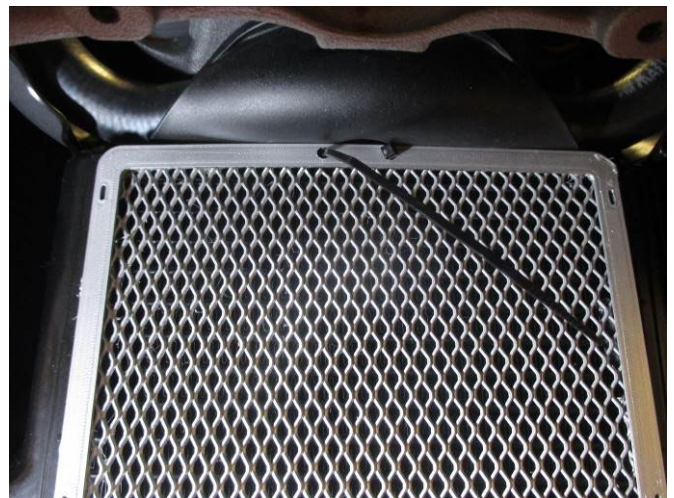

Picture 2



Picture 3

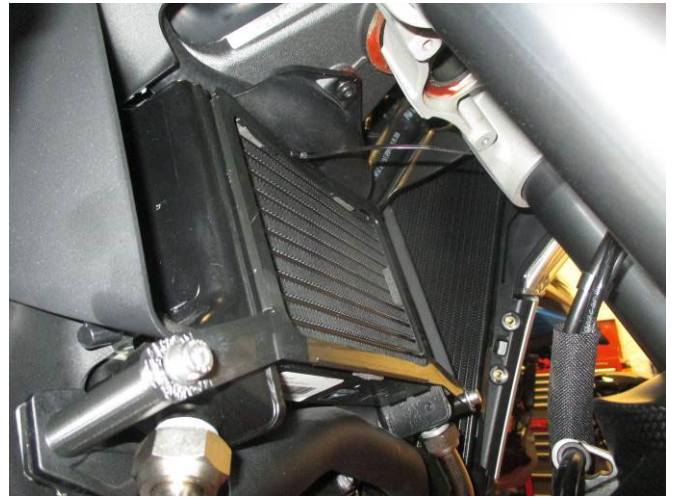

Picture 4

FITTING INSTRUCTIONS

- To begin, Remove the 2 shouldered bolts arrowed in **picture 1**.
- Place the rubber bungs (Item 6) into the holes circled in the image above, making sure that they are in the correct orientation. Next, place one cable tie through either upper slot of the oil cooler guard & offer the oil cooler guard into position.
- The cable tie will need to be looped around the central radiator support; it may help to curl the cable tie before fitting to help route the tie around the back of the support.
- Fasten the cable tie loosely as shown in **pictures 2 and 3**.
- Referring to the **assembly diagram** on page 2, fit the spacers (item 2) into the plastic mount and so the smaller boss sits into the plastic.
- For each side, secure the oil cooler guard and spacer using the button head bolts (item 3) and washers (item 4) as shown in **picture 4**.
- Fully tighten the cable tie at the top of the oil cooler guard so the guard sits against the oil cooler.
- Once secure, trim the excess cable tie using a pair of snips.
- With cable ties now in place, fully tighten the securing bolts to the recommended torque.
- Check all components are secure and all bolts are tight before riding.

See more R&G products for your Motorcycle in the link below:
[R&G Racing | Cleaning/Lubrication - Gleam range for All Vehicles \(rg-racing.com\)](https://www.rg-racing.com)

ISSUE 1 – 31/03/2023 (MH)

CONSUMER NOTICE

The catalogue description and any exhibition of samples are only broad indications of the Products and R&G may make design changes which do not diminish their performance or visual appeal and supplying them in such state shall conform to the order. The Buyer acknowledges no representation or warranty (other than as to title) has been given or will apply to the Products other than those in R&G's order or confirmation and the Buyer confirms it has chosen the Products as being of merchantable quality and suitable for its particular purposes. Where R&G fits the Products or undertakes other services it shall exercise reasonable skill and care and rectify any fault free of charge unless the workmanship has been disturbed. The Buyer is responsible for ensuring that the warranty on the motorcycle is not affected by the fitting of the Products. On return of any defective Products R&G shall at its option either supply a replacement or refund the purchase money but shall not be liable if the Products have been modified or used or maintained otherwise than in accordance with R&G's or manufacturer's instructions and good engineering practice or if the defect arises from accident or neglect. Other than identified above and subject to R&G not limiting its liability for causing death and personal injury, it shall not be liable for indirect or consequential loss and otherwise its liability shall be limited to the amounts paid by the Buyer for the Products or the fitting or service concerned. These terms do not affect the Buyer's statutory rights.

R&G Racing
Unit 1, Shelley's Lane, East Worldham, Alton, Hampshire, GU34 3AQ
Tel: +44 (0)1420 89007 Fax: +44 (0)1420 87301 www.rg-racing.com Email: info@rg-racing.com



R&G RACING RETURNS POLICY (NON-FAULTY GOODS)

Returns must be pre-authorized (if not pre-authorized the return will be rejected). Goods may only be returned direct to us if they were purchased direct from us (customer must prove if necessary). Otherwise to be returned to original vendor. Goods must be in re-sellable condition, in the opinion of R&G Racing. All returns are subject to a 25% restocking and handling fee (25% of the gross value exc. P&P – at the prevailing price at time of purchase). The customer must pay any and all carriage charges. No returns of discontinued products, unless within 14 days of purchase. This policy does not affect your statutory rights and does not refer to faulty goods.



NOTICE DE MONTAGE POUR OCG0051PRO
PROTECTION REFROIDISSEUR D'HUILE

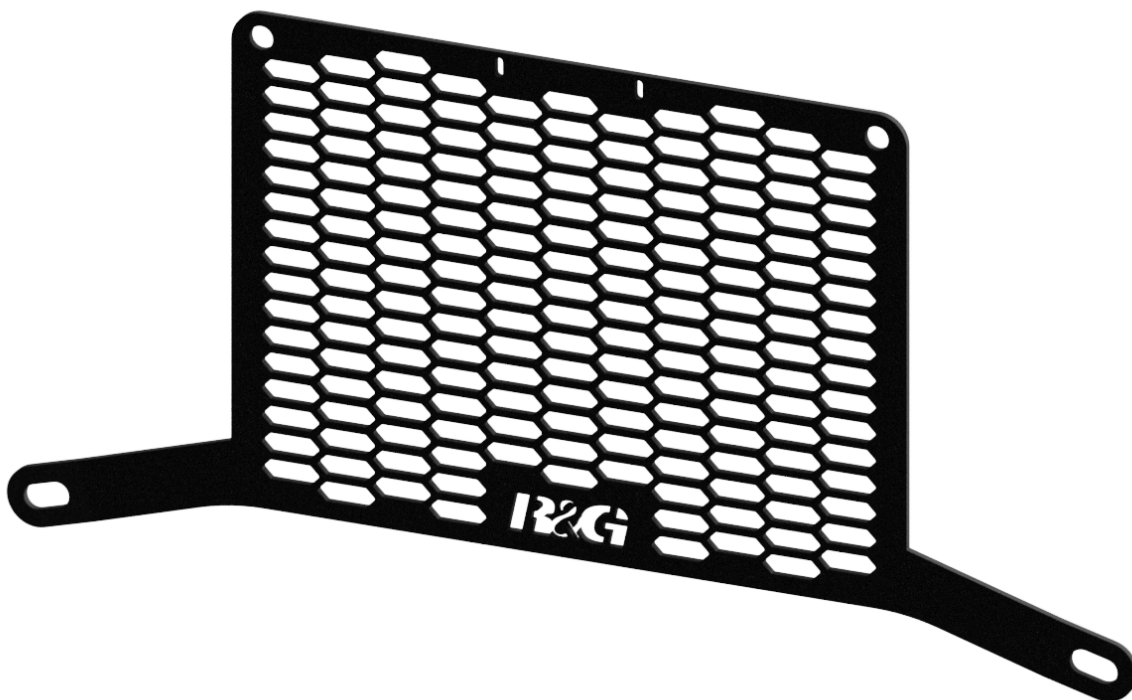

CE KIT CONTIENT LES ARTICLES ILLUSTRÉS ET ÉTIQUETES SUR LA PAGE.

CERTAINES PARTIES PEUVENT ÊTRE PRÉSENTES UNIQUEMENT POUR LA CLARTÉ DES INSTRUCTIONS.

NE PAS PROCÉDER AU MONTAGE TANT QUE VOUS N'ÊTES PAS SÛR QUE TOUTES LES PIÈCES SOIENT PRÉSENTES.

VEUILLEZ LIRE TOUTES LES INSTRUCTIONS AVANT DE CONTINUER.

EN CAS DE DOUTE LORS DU MONTAGE DE NOS PRODUITS, CONSULTEZ UN DE NOS REVENDEURS OU FAITES APPEL À UN TECHNICIEN QUALIFIÉ.

VEUILLEZ NOTER QUE LA FAÇON DONT LE KIT EST EMBALLÉ NE REPRÉSENTE PAS NECESSAIREMENT LA MANIÈRE DE LE MONTER SUR LA MOTO.

SI DES RONDELLES EN CAOUTCHOUC SONT UTILISÉES POUR MAINTENIR LES COMPOSANTS SUR LES BOULONS, ELLES PEUVENT ÊTRE JETÉES.

NOTICE DISPONIBLE AU TÉLÉCHARGEMENT SUR :

WWW.RG-RACING.COM



OUTILS REQUIS	VALEURS DE SERRAGE
<ul style="list-style-type: none"> • CLÉS ALLEN 4mm. • • PINCE À BEC POINTU. • PINCE COUPANTE OU SCISEAUX. 	<p>M4 BOULON = 8Nm</p> <p>M5 BOULON = 12Nm</p> <p>M6 BOULON = 15Nm</p> <p>M8 BOULON = 20Nm</p> <p>M10 BOULON = 40Nm</p> <p>M12 BOULON = 40Nm</p>

LÉGENDE

ARTICLE NO.	DESCRIPTION	QTÉ
ARTICLE 1	OCG0051 PROTECTION REFROIDISSEUR D'HUILE	1
ARTICLE 2	S1387 ENTRETOISE DE PROTECTION REFROIDISSEUR D'HUILE	2
ARTICLE 3	M6X 65MM BOULON	2
ARTICLE 4	M6x12MM RONDELLE	2
ARTICLE 5	CT220 COLLIER DE SERRAGE	2
ARTICLE 6	OEILLET EN CAOUTCHOUC (RB0015)	4

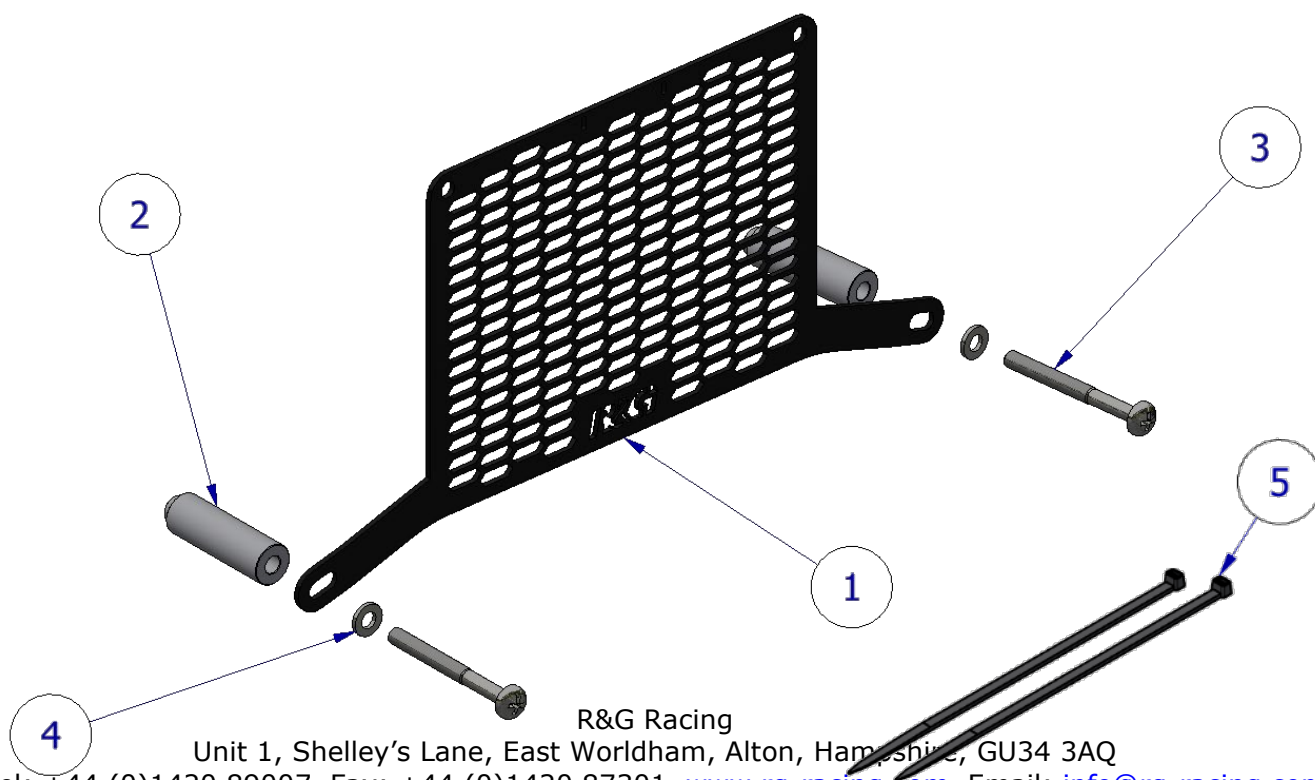

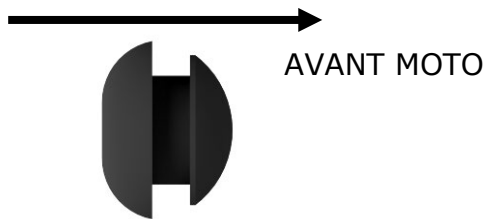
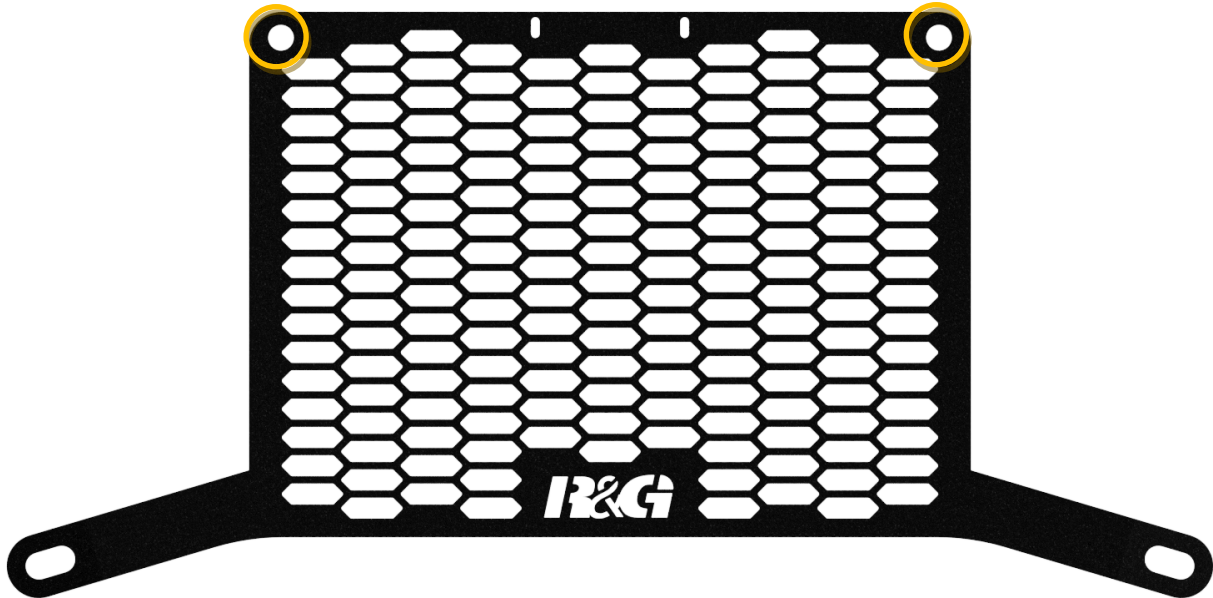

PHOTOS DE MONTAGE

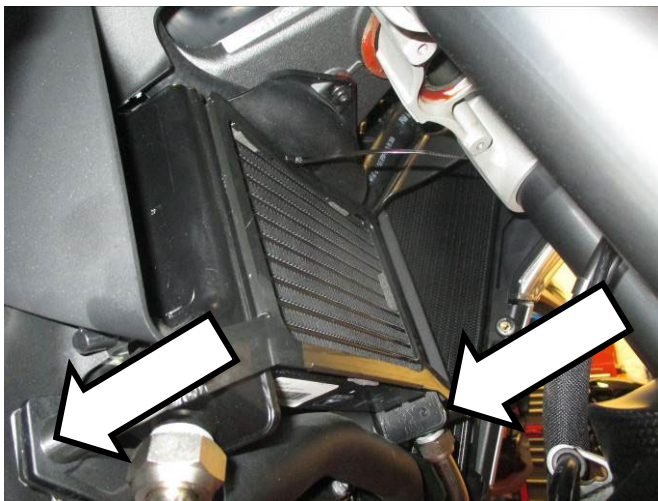

Photo 1

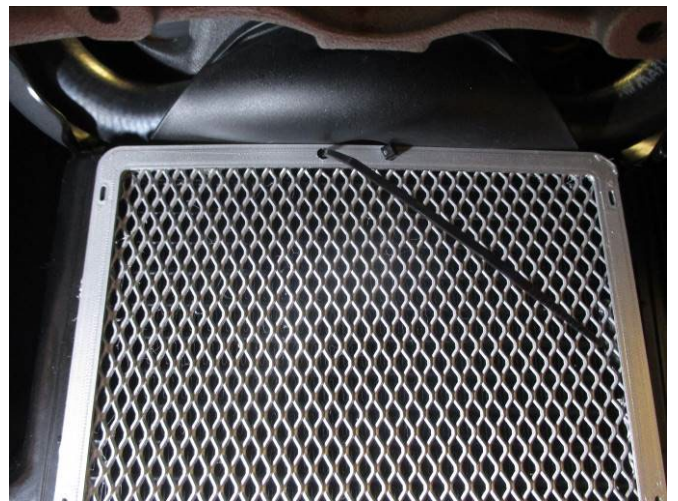

Photo 2



Photo 3



Photo 4

NOTICE DE MONTAGE

- Pour commencer, retirez les 2 boulons à épaulement fléchés sur la photo 1.
- Placez les bouchons en caoutchouc (article 6) dans les trous encerclés sur l'image ci-dessus en vous assurant qu'ils soient dans le bon sens. Ensuite, placez une attache de câble dans l'une ou l'autre des fentes supérieures de la protection du refroidisseur d'huile et placez la protection du refroidisseur d'huile en position.
- Le serre-câble devra être enroulé autour du support central du radiateur ; il peut être utile d'enrouler l'attache de câble avant de l'installer pour faciliter l'acheminement de l'attache autour de l'arrière du support.
- Fixez le serre-câble sans serrer comme indiqué sur les photos 2 et 3.
- En vous référant au schéma de montage de la page 2, placez les entretoises (article 2) dans le support en plastique de manière à ce que le plus petit bossage repose dans le plastique.
- Pour chaque côté, fixez la protection du refroidisseur d'huile et l'entretoise à l'aide des boulons à tête ronde (article 3) et des rondelles (article 4) comme indiqué sur la photo 4.
- Serrez complètement l'attache de câble en haut de la protection du refroidisseur d'huile afin que la protection repose contre le refroidisseur d'huile.
- Une fois fixé, coupez l'excédent d'attache de câble à l'aide d'une paire de cisailles.
- Une fois les serre-câbles en place, serrez complètement les boulons de fixation au couple recommandé.
- Vérifiez que tous les composants soient sécurisés et que tous les boulons soient bien serrés avant de rouler.

Voir plus de produits R&G pour votre moto via ce lien :
[R&G Racing | Cleaning/Lubrication - Gleam range for All Vehicles \(rg-racing.com\)](https://www.rg-racing.com)

ISSUE 1 – 31/03/2023 (MH)

CONSUMER NOTICE

The catalogue description and any exhibition of samples are only broad indications of the Products and R&G may make design changes which do not diminish their performance or visual appeal and supplying them in such state shall conform to the order. The Buyer acknowledges no representation or warranty (other than as to title) has been given or will apply to the Products other than those in R&G's order or confirmation and the Buyer confirms it has chosen the Products as being of merchantable quality and suitable for its particular purposes. Where R&G fits the Products or undertakes other services it shall exercise reasonable skill and care and rectify any fault free of charge unless the workmanship has been disturbed. The Buyer is responsible for ensuring that the warranty on the motorcycle is not affected by the fitting of the Products. On return of any defective Products R&G shall at its option either supply a replacement or refund the purchase money but shall not be liable if the Products have

R&G Racing

Unit 1, Shelley's Lane, East Worldham, Alton, Hampshire, GU34 3AQ

Tel: +44 (0)1420 89007 Fax: +44 (0)1420 87301 www.rg-racing.com Email: info@rg-racing.com



been modified or used or maintained otherwise than in accordance with R&G's or manufacturer's instructions and good engineering practice or if the defect arises from accident or neglect. Other than identified above and subject to R&G not limiting its liability for causing death and personal injury, it shall not be liable for indirect or consequential loss and otherwise its liability shall be limited to the amounts paid by the Buyer for the Products or the fitting or service concerned. These terms do not affect the Buyer's statutory rights.

R&G RACING RETURNS POLICY (NON-FAULTY GOODS)

Returns must be pre-authorized (if not pre-authorized the return will be rejected). Goods may only be returned direct to us if they were purchased direct from us (customer must prove if necessary). Otherwise to be returned to original vendor. Goods must be in re-sellable condition, in the opinion of R&G Racing. All returns are subject to a 25% restocking and handling fee (25% of the gross value exc. P&P - at the prevailing price at time of purchase). The customer must pay any and all carriage charges. No returns of discontinued products, unless within 14 days of purchase. This policy does not affect your statutory rights and does not refer to faulty goods.



MONTAGEANLEITUNG FÜR OCG0051PRO **ÖLKÜHLERSCHUTZ**

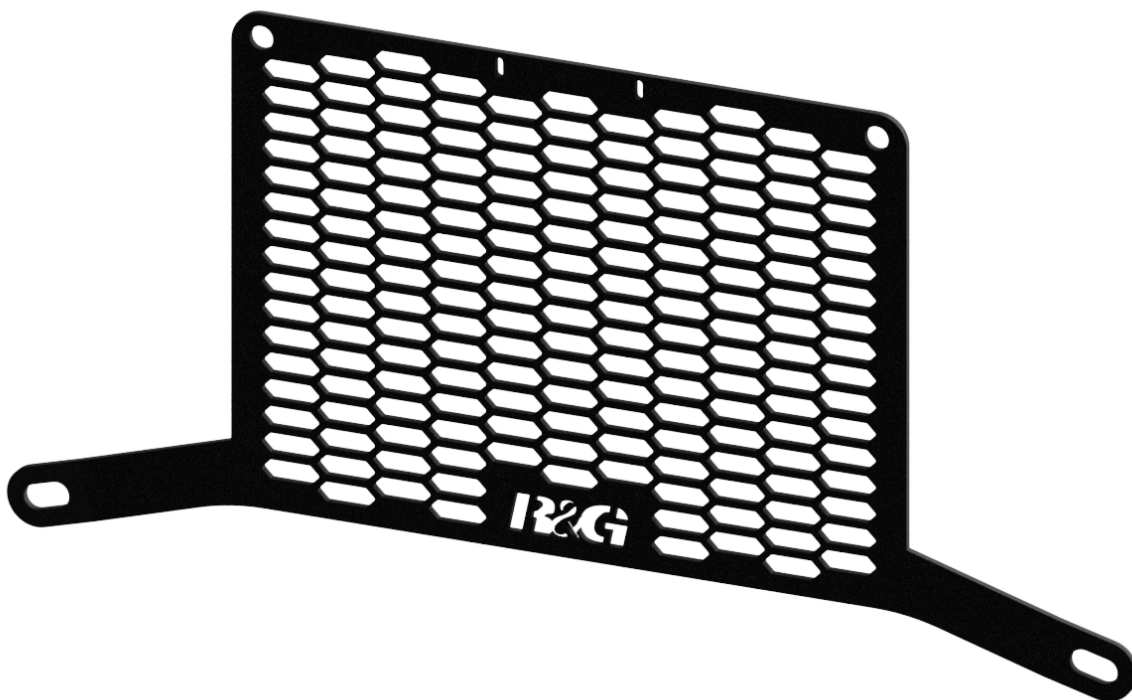

ALLE KIT-TEILE SIND AUF DEN NACHFOLGENDEN SEITEN ABGEBILDET UND GEKENNZEICHNET.

DIE ABGEBILDETEN TEILE DIENEN LEDIGLICH ZUR ERKLÄRUNG.

ÜBERPRÜFEN SIE ZUERST, DASS ALLE TEILE VORHANDEN SIND.

LESEN SIE DIE MONTAGEANLEITUNG KOMPLETT DURCH, BEVOR SIE ANFANGEN.

WENN SIE BEI DER MONTAGE DIESES PRODUKTES UNSICHER SIND, BITTE EINEN UNSERER HÄNDLER KONTAKTIEREN ODER DAS KIT VON EINEM QUALIFIZIERTEN ZWEIRAD-MECHANIKER MONTIEREN LASSEN.

DIE VERPACKUNG DER TEILE STELLT NICHT DIE REIHENFOLGE DER MONTAGE DAR.

HINWEIS FÜR KITS MIT PLASTIKUNTERLEGSCHREIBEN AN DEN SCHRAUBEN –
DIESE PLASTIK-UNTERLEGSCHREIBEN WERDEN NICHT FÜR DEN EINBAU BENÖTIGT.

EINE DIGITALE VERSION DIESER MONTAGEANLEITUNG KANN AUF FOLGENDER SEITE HERUNTERGELADEN WERDEN:

WWW.RG-RACING.COM

R&G Racing

Unit 1, Shelley's Lane, East Worldham, Alton, Hampshire, GU34 3AQ

Tel: +44 (0)1420 89007 Fax: +44 (0)1420 87301 www.rg-racing.com Email: info@rg-racing.com



<p><u>SIE BENÖTIGEN FOLGENDES WERKZEUG</u></p> <ul style="list-style-type: none"> • SATZ INBUSSCHLÜSSEL INKL. 4mm <ul style="list-style-type: none"> • SPITZZANGE • SEITENSCHNEIDER ODER SCHERE 	<p><u>ALLGEM. ANZUGSDREHMOMENT:</u></p> <p>M4 SCHRAUBE = 8Nm M5 SCHRAUBE = 12Nm M6 SCHRAUBE = 15Nm M8 SCHRAUBE = 20Nm M10 SCHRAUBE = 40Nm M12 SCHRAUBE = 40Nm</p>
--	---

LIEFERUMFANG

ARTIKEL NR.	BESCHREIBUNG	MENGE
ARTIKEL 1	OCG0051 ÖLKÜHLERSCHUTZ	1
ARTIKEL 2	S1387 DISTANZHALTER FÜR ÖLKÜHLERSCHUTZ	2
ARTIKEL 3	M6X 65MM INBUSSCHRAUBE	2
ARTIKEL 4	M6x12MM O/D UNTERLEGSCHIEBE	2
ARTIKEL 5	CT220 KABELBINDER	2
ARTIKEL 6	GUMMISTOPFEN (RB0015)	4

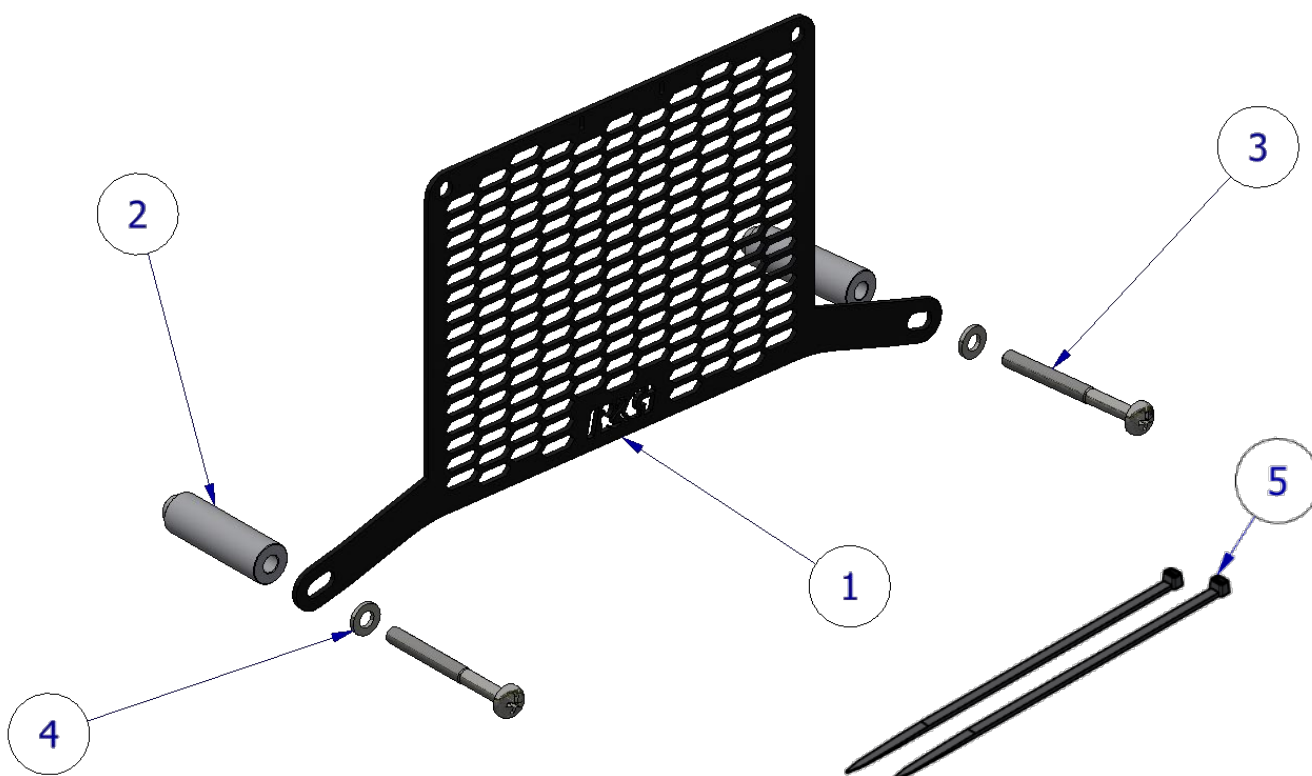

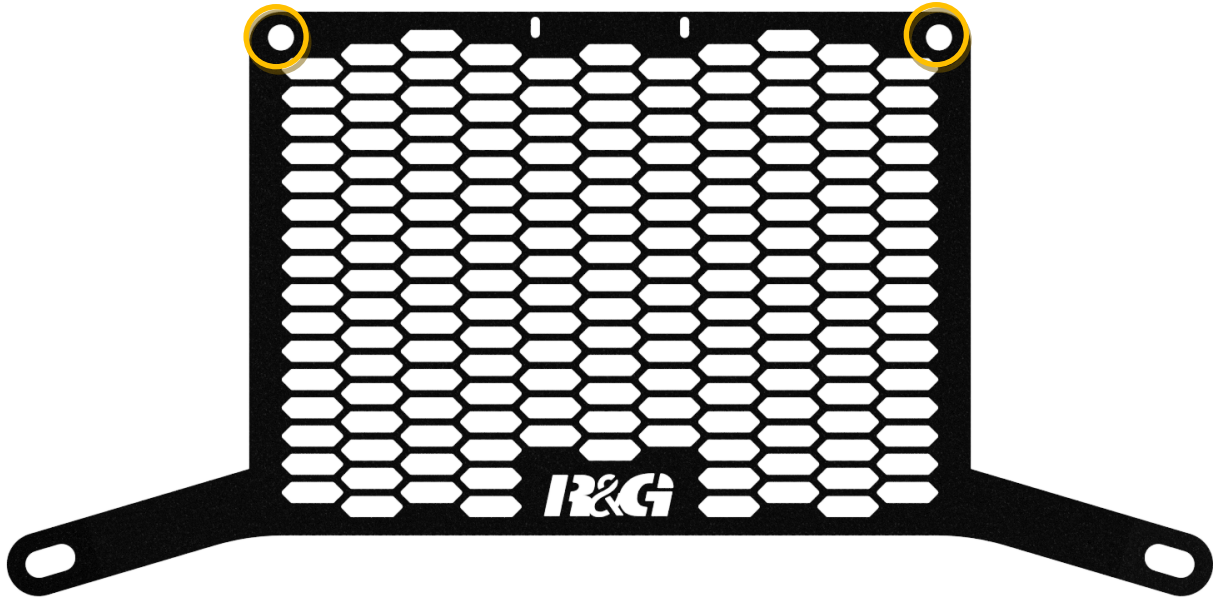

MOTORRAD VORNE

MONTAGE ABBILDUNGEN



Abbildung 1



Abbildung 2

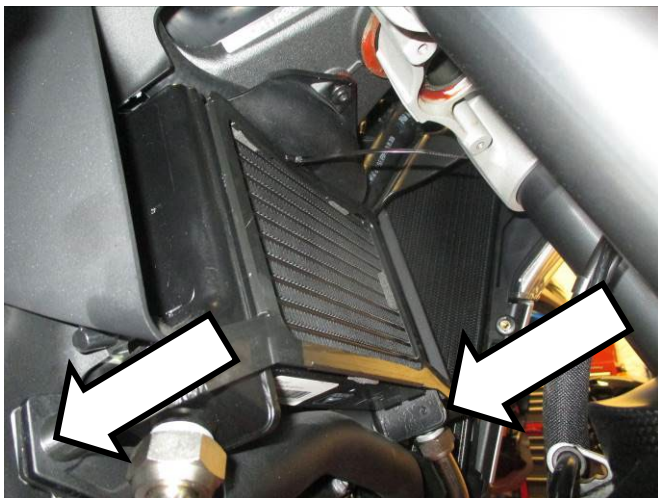

Abbildung 3



Abbildung 4

MONTAGEANLEITUNG

- Entfernen Sie zuerst die zwei Schrauben, die in **Abbildung 1** mit Pfeilen gekennzeichnet sind.
- Die Gummistopfen (Artikel 6) in die Öffnungen einsetzen, die in der Abbildung oben mit Kreisen gekennzeichnet sind. Stellen Sie sicher, dass sie korrekt ausgerichtet sind. Danach, einen Kabelbinder in eine der oberen Schlitze des Ölkühlerschutzes einsetzen und den Ölkühlerschutz in Position bringen.
- Der Kabelbinder muss um die mittige Halterung des Kühlers gewickelt werden – eventuell hilft es, den Kabelbinder vorher spiralig einzurollen, um ihn einfacher hinten um die Halterung zu führen.
- Den Kabelbinder lose befestigen wie in den **Abbildungen 2 und 3** abgebildet.
- Entsprechend der **Zeichnung Zusammenbau** auf Seite 2, die Distanzhalter (Artikel 2) in die Kunststoffhalterung einsetzen, sodass der kleinere Einsatz in den Kunststoff passt.
- Den Ölkühlerschutz und Distanzhalter an beiden Seiten mit einer Inbusschraube (Artikel 3) und Unterlegscheibe (Artikel 4) befestigen wie in **Abbildung 4** abgebildet.
- Den Kabelbinder oben am Ölkühlerschutz komplett festziehen, sodass der Kühlerschutz am Ölkühler anliegt.
- Wenn alles sicher fixiert ist, das überschüssige Kabelband mit einem Seitenscheider oder einer Schere abschneiden.
- Nachdem alle Kabelbinder montiert sind, die Sicherungsschrauben mit dem empfohlenen Anzugsdrehmoment befestigen.
- Überprüfen Sie, dass alle Komponenten sicher befestigt sind und alle Schrauben fest angezogen sind, bevor Sie mit dem Motorrad fahren.

Klicken Sie hier, um weitere R&G Produkte für Ihr Motorrad zu finden:

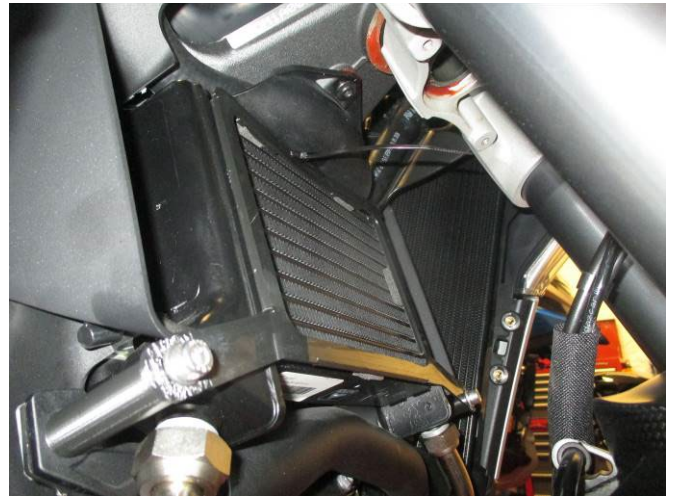
[R&G Racing | Cleaning/Lubrication - Gleam range for All Vehicles \(rg-racing.com\)](https://www.rg-racing.com)

AUSGABE 1 – 31/03/2023 (MH)

CONSUMER NOTICE

The catalogue description and any exhibition of samples are only broad indications of the Products and R&G may make design changes which do not diminish their performance or visual appeal and supplying them in such state shall conform to the order. The Buyer acknowledges no representation or warranty (other than as to title) has been given or will apply to the Products other than those in R&G's order or confirmation and the Buyer confirms it has chosen the Products as being of merchantable quality and suitable for its particular purposes. Where R&G fits the Products or undertakes other services it shall exercise reasonable skill and care and rectify any fault free of charge unless the workmanship has been disturbed. The Buyer is responsible for

R&G Racing

Unit 1, Shelley's Lane, East Worldham, Alton, Hampshire, GU34 3AQ

Tel: +44 (0)1420 89007 Fax: +44 (0)1420 87301 www.rg-racing.com Email: info@rg-racing.com



ensuring that the warranty on the motorcycle is not affected by the fitting of the Products. On return of any defective Products R&G shall at its option either supply a replacement or refund the purchase money but shall not be liable if the Products have been modified or used or maintained otherwise than in accordance with R&G's or manufacturer's instructions and good engineering practice or if the defect arises from accident or neglect. Other than identified above and subject to R&G not limiting its liability for causing death and personal injury, it shall not be liable for indirect or consequential loss and otherwise its liability shall be limited to the amounts paid by the Buyer for the Products or the fitting or service concerned. These terms do not affect the Buyer's statutory rights.

R&G RACING RETURNS POLICY (NON-FAULTY GOODS)

Returns must be pre-authorized (if not pre-authorized the return will be rejected). Goods may only be returned direct to us if they were purchased direct from us (customer must prove if necessary). Otherwise to be returned to original vendor. Goods must be in re-sellable condition, in the opinion of R&G Racing. All returns are subject to a 25% restocking and handling fee (25% of the gross value exc. P&P – at the prevailing price at time of purchase). The customer must pay any and all carriage charges. No returns of discontinued products, unless within 14 days of purchase. This policy does not affect your statutory rights and does not refer to faulty goods.