



**FITTING INSTRUCTIONS FOR OCG0057PRO**  
**OIL COOLER GUARD**



**THIS KIT CONTAINS THE ITEMS PICTURED AND LABELLED OVER PAGE.**

SOME PARTS MAY BE SHOWN FOR CLARITY OF INSTRUCTIONS ONLY.

DO NOT PROCEED UNTIL YOU ARE SURE ALL PARTS ARE PRESENT.

**PLEASE READ ALL INSTRUCTIONS BEFORE PROCEEDING.**

**IF IN ANY DOUBT WHEN FITTING OUR PRODUCTS, CONSULT ONE OF OUR DEALERS  
OR HAVE FITTED BY A QUALIFIED TECHNICIAN.**

PLEASE NOTE THAT THE WAY THE KIT IS PACKED DOES NOT NECESSARILY REPRESENT THE WAY OF  
MOUNTING TO THE BIKE.

IN THE EVENT OF RUBBER WASHERS BEING USED TO HOLD COMPONENTS ONTO BOLTS,

THESE RUBBER WASHERS CAN BE THROWN AWAY.

**DIGITAL COPIES OF THESE INSTRUCTIONS ARE AVAILABLE FROM:**

[WWW.RG-RACING.COM](http://WWW.RG-RACING.COM)



<b><u>TOOLS REQUIRED</u></b>	<b><u>GENERAL TORQUE SETTINGS</u></b>
<ul style="list-style-type: none"> <li>• 4mm ALLEN KEY</li> <li>• CABLE CUTTERS OR SCISSORS.</li> </ul>	<p>M4 BOLT = 8Nm                      M5 BOLT = 12Nm                      M6 BOLT = 15Nm                      M8 BOLT = 20Nm                      M10 BOLT = 40Nm                      M12 BOLT = 40Nm</p>

**LEGEND**

ITEM NO.	DESCRIPTION	QTY
ITEM 1	OCG0057 OIL COOLER GUARD	1
ITEM 2	RUBBER BUNG (RB0015)	2

**ASSEMBLY DIAGRAM**

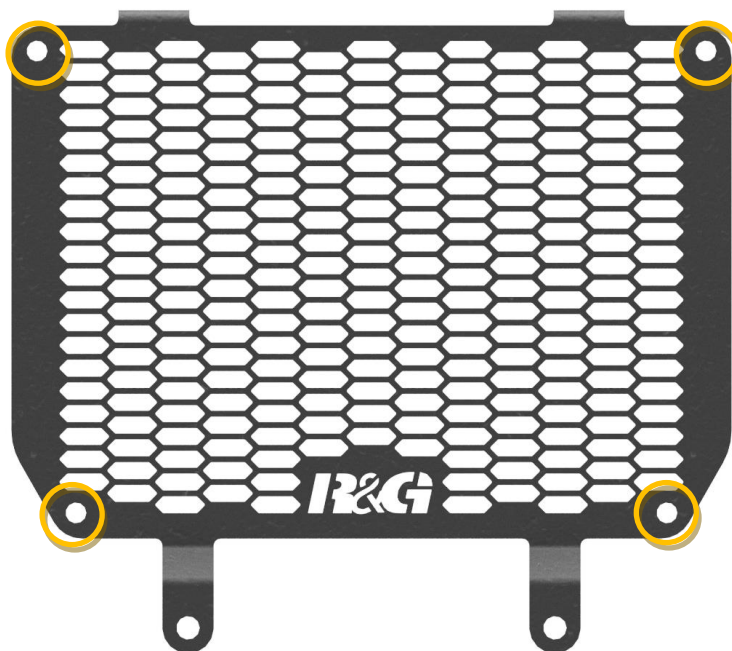

FRONT OF BIKE



**FITTING PICTURES**

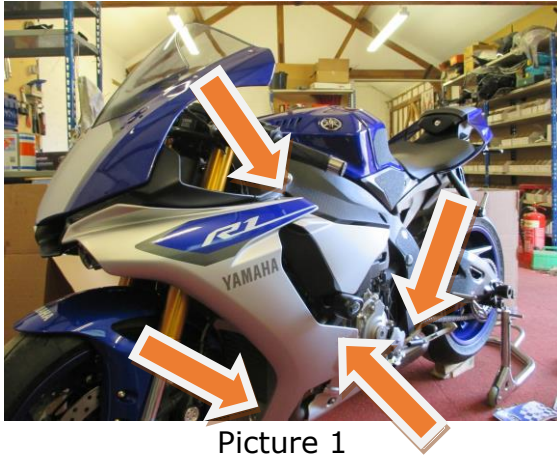

Picture 1



Picture 2

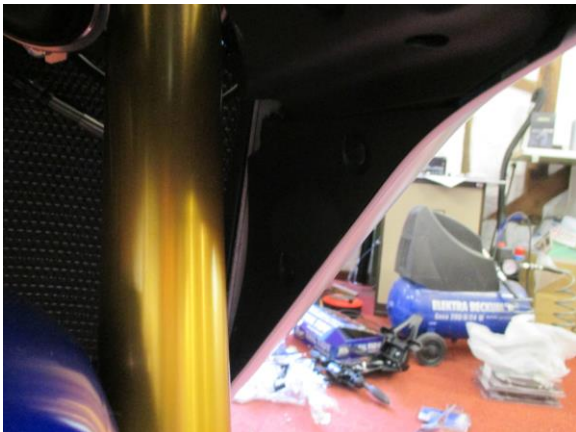

Picture 3

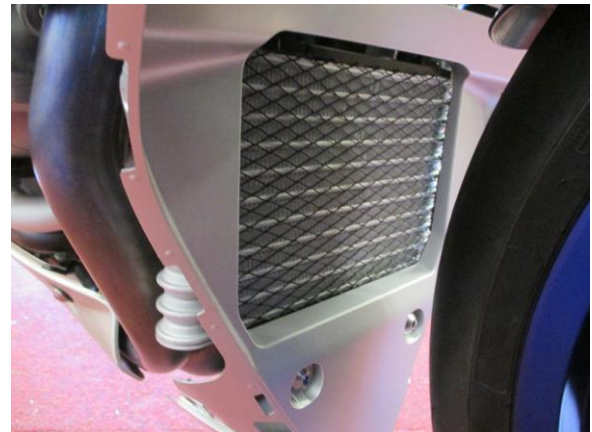

Picture 4

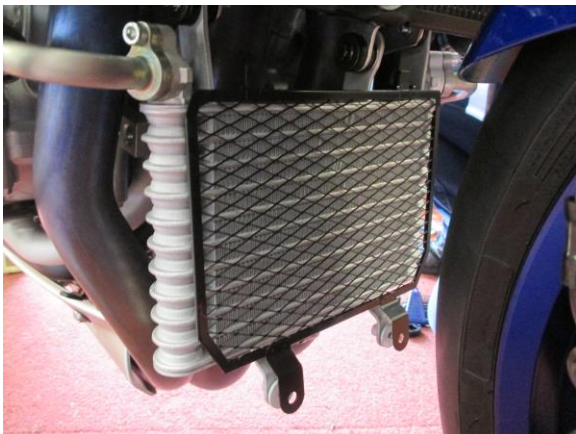

Picture 5



## **FITTING INSTRUCTIONS**

- To fit R&G oil cooler guard to the bike, insert the 4x rubber grommets into the guard in the holes circled in yellow in **Fitting Diagram** if they do not come already installed.
- Remove the fairings from the bike. To do this on the left side of the bike, remove the four quick release fixtures on the fairing, as arrowed in **picture 1**. On the inside of the fairing, there are four push rivets to be removed, as shown in **pictures 2 & 3**, before the panel can gently slide forward and be removed from the bike.
- Repeat this process to remove the fairing from the right side of the bike. *Please note there are only three push rivets on the right.*
- Remove the two bolts that secure the oil cooler cowling in place, as shown in **picture 4**.
- Remove the cowling by lifting upwards to clear the two location tabs on the oil cooler, as shown in **picture 5**.
- Remove the OEM oil cooler guard by lifting upwards, releasing the two mounting tabs at the top from the slots on the guard.
- Take the R&G Oil Cooler Guard and fit in the same way as the OEM guard was removed.
- Re-fit the oil cooler cowling and tighten the two bolts, securing the oil cooler guard in place.
- Re-fit the fairings to both sides of the bike.

ISSUE 1 - 25/01/2024 (MH)

### **CONSUMER NOTICE**

The catalogue description and any exhibition of samples are only broad indications of the Products and R&G may make design changes which do not diminish their performance or visual appeal and supplying them in such state shall conform to the order. The Buyer acknowledges no representation or warranty (other than as to title) has been given or will apply to the Products other than those in R&G's order or confirmation and the Buyer confirms it has chosen the Products as being of merchantable quality and suitable for its particular purposes. Where R&G fits the Products or undertakes other services it shall exercise reasonable skill and care and rectify any fault free of charge unless the workmanship has been disturbed. The Buyer is responsible for ensuring that the warranty on the motorcycle is not affected by the fitting of the Products. On return of any defective Products R&G shall at its option either supply a replacement or refund the purchase money but shall not be liable if the Products have been modified or used or maintained otherwise than in accordance with R&G's or manufacturer's instructions and good engineering practice or if the defect arises from accident or neglect. Other than identified above and subject to R&G not limiting its liability for causing death and personal injury, it shall not be liable for indirect or consequential loss and otherwise its liability shall be limited to the amounts paid by the Buyer for the Products or the fitting or service concerned. These terms do not affect the Buyer's statutory rights.

### **R&G RACING RETURNS POLICY (NON-FAULTY GOODS)**

Returns must be pre-authorized (if not pre-authorized the return will be rejected). Goods may only be returned direct to us if they were purchased direct from us (customer must prove if necessary). Otherwise to be returned to original vendor. Goods must be in re-sellable condition, in the opinion of R&G Racing. All returns are subject to a 25% restocking and handling fee (25% of the gross value exc. P&P - at the prevailing price at time of purchase). The customer must pay any and all carriage charges. No returns of discontinued products, unless within 14 days of purchase. This policy does not affect your statutory rights and does not refer to faulty goods.

## **NOTICE DE MONTAGE POUR OCG0057PRO** **PROTECTION REFROIDISSEUR D'HUILE**







**CE KIT CONTIENT LES ARTICLES ILLUSTRÉS ET ÉTIQUETES SUR LA PAGE.**

CERTAINES PARTIES PEUVENT ÊTRE PRÉSENTES UNIQUEMENT POUR LA CLARTE DES INSTRUCTIONS.

NE PAS PROCÉDER AU MONTAGE TANT QUE VOUS N'ÊTES PAS SÛR QUE TOUTES LES PIÈCES SOIENT PRÉSENTES.

**VEUILLEZ LIRE TOUTES LES INSTRUCTIONS AVANT DE CONTINUER.**

**EN CAS DE DOUTE LORS DU MONTAGE DE NOS PRODUITS, CONSULTEZ UN DE NOS REVENDEURS OU FAITES APPEL À UN TECHNICIEN QUALIFIÉ.**

VEUILLEZ NOTER QUE LA FAÇON DONT LE KIT EST EMBALLÉ NE REPRÉSENTE PAS NECESSAIREMENT LA MANIÈRE DE LE MONTER SUR LA MOTO.

SI DES RONDELLES EN CAOUTCHOUC SONT UTILISÉES POUR MAINTENIR LES COMPOSANTS SUR LES BOULONS, ELLES PEUVENT ÊTRE JETÉES.

**NOTICE DISPONIBLE AU TÉLÉCHARGEMENT SUR :**

[WWW.RG-RACING.COM](http://WWW.RG-RACING.COM)

<b><u>OUTILS REQUIS</u></b>	<b><u>VALEURS DE SERRAGE</u></b>
<ul style="list-style-type: none"> <li>• Clés Allen 4mm</li> <li>• Coupe câble ou ciseaux</li> </ul>	M4 BOULON = 8Nm M5 BOULON = 12Nm M6 BOULON = 15Nm M8 BOULON = 20Nm M10 BOULON = 40Nm M12 BOULON = 40Nm

**LÉGENDE**

R&G Racing

Unit 1, Shelley's Lane, East Worldham, Alton, Hampshire, GU34 3AQ

Tel: +44 (0)1420 89007 Fax: +44 (0)1420 87301 [www.rg-racing.com](http://www.rg-racing.com) Email: [info@rg-racing.com](mailto:info@rg-racing.com)



ARTICLE NO.	DESCRIPTION	QTÉ
ARTICLE 1	OCG0057 PROTECTION REFROIDISSEUR D'HUILE	1
ARTICLE 2	OEILLET EN CAOUTCHOUC (RB0015)	2

### SCHÉMA D'ENSEMBLE

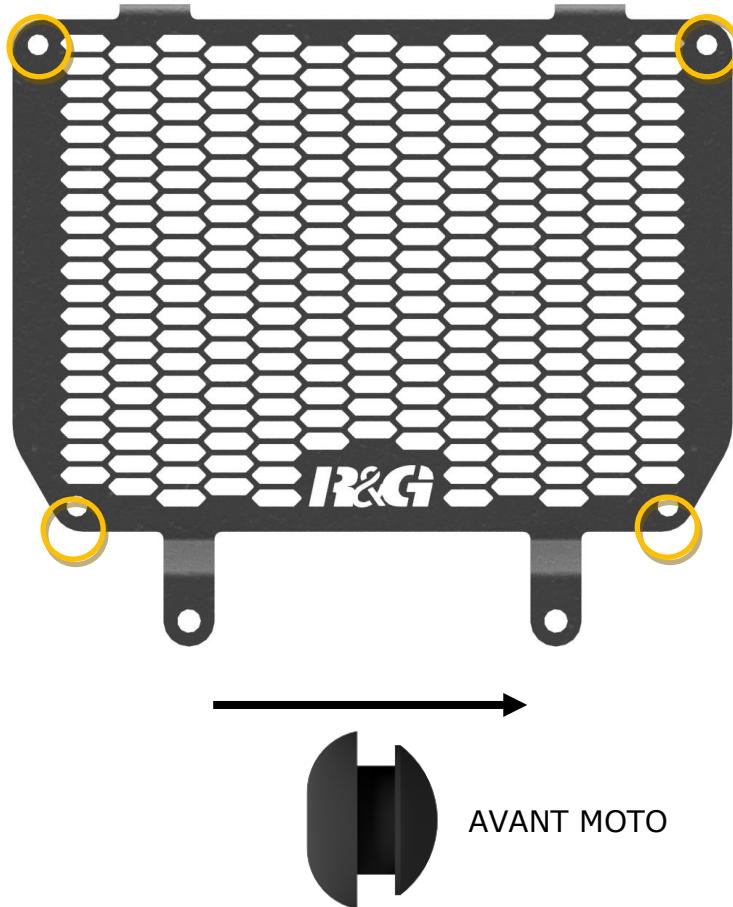

### PHOTOS DE MONTAGE



Photo 1



Photo 2

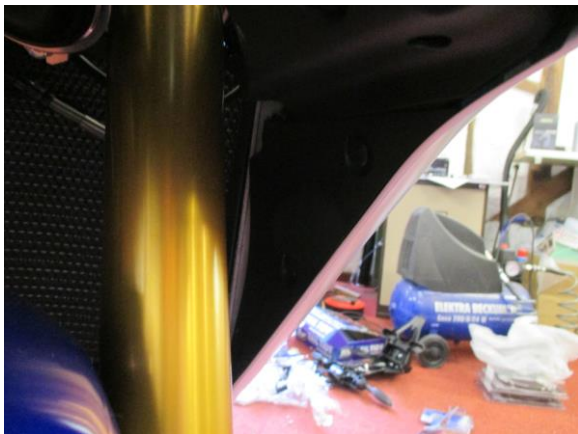

Photo 3

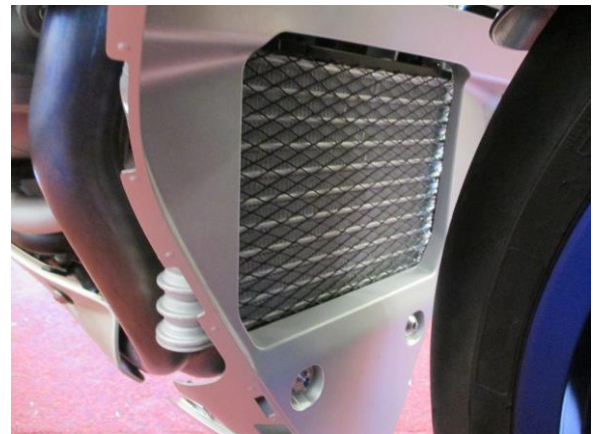

Photo 4



Photo 5

**NOTICE DE MONTAGE**

R&G Racing  
Unit 1, Shelley's Lane, East Worldham, Alton, Hampshire, GU34 3AQ  
Tel: +44 (0)1420 89007 Fax: +44 (0)1420 87301 [www.rg-racing.com](http://www.rg-racing.com) Email: [info@rg-racing.com](mailto:info@rg-racing.com)



- Pour installer la protection du refroidisseur d'huile R&G sur la moto, insérez les 4 œillets en caoutchouc dans la protection dans les trous entourés en jaune sur le schéma de montage s'ils ne sont pas déjà installés.
- Retirez les carénages de la moto. Pour ce faire, sur le côté gauche de la moto, retirez les quatre fixations rapides sur le carénage, comme indiqué par la flèche sur la photo 1. A l'intérieur du carénage, il y a quatre rivets poussoirs à retirer, comme indiqué sur les photos 2 et 3, avant que le panneau puisse glisser doucement vers l'avant et être retiré de la moto.
- Répétez ce processus pour retirer le carénage du côté droit de la moto. Veuillez noter qu'il n'y a que trois rivets poussoirs sur la droite.
- Retirez les deux boulons qui maintiennent le capot du refroidisseur d'huile en place, comme indiqué sur la photo 4.
- Retirez le capot en le soulevant vers le haut pour dégager les deux languettes d'emplacement sur le refroidisseur d'huile, comme indiqué sur la photo 5.
- Retirez la protection du refroidisseur d'huile d'origine en la soulevant vers le haut, libérant les deux languettes de montage en haut des fentes de la protection.
- Prenez la protection du refroidisseur d'huile R&G et installez-la de la même manière que la protection d'origine a été retirée.
- Remettez en place le capot du refroidisseur d'huile et serrez les deux boulons pour fixer la protection du refroidisseur d'huile en place.
- Remontez les carénages des deux côtés de la moto.

ISSUE 1 - 25/01/2024 (MH)

#### **CONSUMER NOTICE**

The catalogue description and any exhibition of samples are only broad indications of the Products and R&G may make design changes which do not diminish their performance or visual appeal and supplying them in such state shall conform to the order. The Buyer acknowledges no representation or warranty (other than as to title) has been given or will apply to the Products other than those in R&G's order or confirmation and the Buyer confirms it has chosen the Products as being of merchantable quality and suitable for its particular purposes. Where R&G fits the Products or undertakes other services it shall exercise reasonable skill and care and rectify any fault free of charge unless the workmanship has been disturbed. The Buyer is responsible for ensuring that the warranty on the motorcycle is not affected by the fitting of the Products. On return of any defective Products R&G shall at its option either supply a replacement or refund the purchase money but shall not be liable if the Products have been modified or used or maintained otherwise than in accordance with R&G's or manufacturer's instructions and good engineering practice or if the defect arises from accident or neglect. Other than identified above and subject to R&G not limiting its liability for causing death and personal injury, it shall not be liable for indirect or consequential loss and otherwise its liability shall be limited to the amounts paid by the Buyer for the Products or the fitting or service concerned. These terms do not affect the Buyer's statutory rights.

#### **R&G RACING RETURNS POLICY (NON-FAULTY GOODS)**

Returns must be pre-authorized (if not pre-authorized the return will be rejected). Goods may only be returned direct to us if they were purchased direct from us (customer must prove if necessary). Otherwise to be returned to original vendor. Goods must be in re-sellable condition, in the opinion of R&G Racing. All returns are subject to a 25% restocking and handling fee (25% of the gross value exc. P&P - at the prevailing price at time of purchase). The customer must pay any and all carriage charges. No returns of discontinued products, unless within 14 days of purchase. This policy does not affect your statutory rights and does not refer to faulty goods.

R&G Racing

Unit 1, Shelley's Lane, East Worldham, Alton, Hampshire, GU34 3AQ

Tel: +44 (0)1420 89007 Fax: +44 (0)1420 87301 [www.rg-racing.com](http://www.rg-racing.com) Email: [info@rg-racing.com](mailto:info@rg-racing.com)