



**FITTING INSTRUCTIONS FOR TH0002**  
**TIE-DOWN HOOKS FOR DUCATI PANIGALE (ALL MODELS)**



**THIS KIT CONTAINS THE ITEMS PICTURED AND LABELLED BELOW.**  
**DO NOT PROCEED UNTIL YOU ARE SURE ALL PARTS ARE PRESENT.**

Please note that the way the kit is packed does not necessarily represent the way of mounting to the bike.

THE PARTS SHOWN MAY BE REPRESENTATIVE ONLY (FOR CLARITY OF INSTRUCTIONS ONLY).

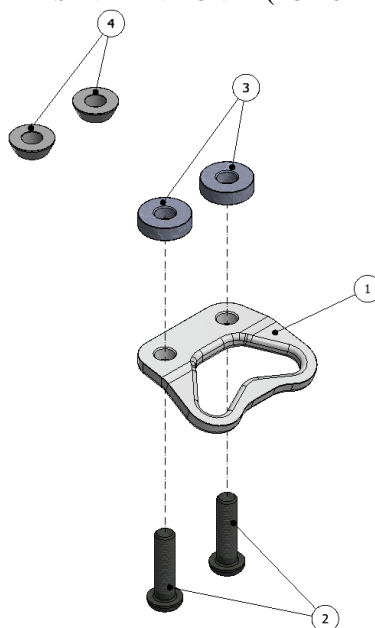

R&G Racing

Unit 1, Shelley's Lane, East Worldham, Alton, Hampshire, GU34 3AQ

Tel: +44 (0)1420 89007 Fax: +44 (0)1420 87301 [www.rg-racing.com](http://www.rg-racing.com) Email: [info@rg-racing.com](mailto:info@rg-racing.com)



### **LEGEND**

ITEM 1 = TIE-DOWN HOOK (SMW0059) (x1).

ITEM 2 = M8 x 30mm LONG COUNTERSUNK BOLT (x2).

ITEM 3 = SPACERS (S0623 – 6mm LONG) (x2).

ITEM 4 = SPACERS (S0940 – 6mm LONG TAPERED) (x2). *\*TO BE USED ON 959 WHEN NOT USING EXHAUST HANGER*

ITEM 5 = M8 x 20mm LONG COUNTERSUNK BOLT (x2). *(NOT SHOWN) \*TO BE USED ON 899 ONLY IN PLACE OF M8 x 30mm LONG COUNTERSUNK BOLTS*

Please note that in cases where kits are packed with rubber washers holding the components onto the bolt – *the rubber washers should be thrown away!*

### **TOOLS REQUIRED**

- Socket set to include 5 & 6mm socket and wrench and extensions.
- Socket set to include 12mm socket (only for use on 959).

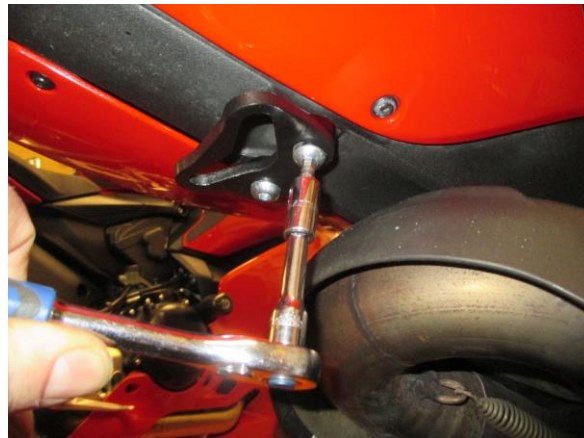

Picture 1



Picture 2



Picture 3



### **GENERAL TORQUE SETTINGS**

- M4 BOLT = 8Nm
- M5 BOLT = 12Nm
- M6 BOLT = 15Nm
- M8 BOLT = 20Nm
- M10 BOLT = 40Nm

### **FITTING INSTRUCTIONS**

#### **If fitting to the 1199 & 1299**

- Position the two M8 x 30mm long countersunk bolts through the two mounting holes of the tie-down hook (SMW0059) (*ensuring the part bends outwards away from the bike*) and then through the two standard spacers (item 3 – S0623 – 6mm long), as shown in the exploded diagram on page 1.
- Take this assembly and offer it up to the bike, before loosely tightening the two bolts into the two subframe threaded bosses on the underside of the seat unit, as shown in pictures 1 & 2.
- Ensure the part is correctly fitted before tightening both bolts to the recommended torque values.

#### **If fitting to the 899**

- Position the two M8 x 20mm long countersunk bolts through the two mounting holes of the tie-down hook (SMW0059) (*ensuring the part bends outwards away from the bike*) and then through the two standard spacers (item 3 – S0623 – 6mm long), as shown in the exploded diagram on page 1.
- Take this assembly and offer it up to the bike, before loosely tightening the two bolts into the two subframe threaded bosses on the underside of the seat unit, as shown in pictures 1 & 2.
- Ensure the part is correctly fitted before tightening both bolts to the recommended torque values.

#### **If fitting to the 959 with exhaust hanger**

- Remove the two rearward mounting bolts for the exhaust hanger and offer the tie-down hook into position (*ensuring the part bends outwards away from the bike*) before fitting the two M8 x 30mm long countersunk bolts through the two mounting holes of the tie-down hook and exhaust hanger, before tightening into the two subframe threaded bosses on the underside of the seat unit, as shown in picture 3.
- Ensure the part is correctly fitted before tightening both bolts to the recommended torque values.

#### **If fitting to the 959 without exhaust hanger**

- If removing the pillion footrest mounting bracket and not re-fitting an exhaust hanger, use the two tapered spacers supplied (item 4 – S0940 – 6mm long) and fit between the heatshield and rear subframe front mounts and tighten using the OEM bolts.
  - Position the two M8 x 30mm long countersunk bolts through the two mounting holes of the tie-down hook (SMW0059) (*ensuring the part bends outwards away from the bike*) and then through the two standard spacers (item 3 – S0623 – 6mm long), as shown in the exploded diagram on page 1.
  - Take this assembly and offer it up to the bike, before loosely tightening the two bolts into the two subframe threaded bosses on the underside of the seat unit, as shown in pictures 1 & 2.
  - Ensure the part is correctly fitted before tightening both bolts to the recommended torque values.
- We recommend that fabric from the straps be in contact with the product, as opposed to the hook on the end of the strap. This will increase the lifespan of the protective coating on the product.
- Do not overtighten straps attached to the product, as it would be possible to bend or break the product with excessive force. If in any doubt please consult a professional.



- R&G cannot be held liable for any breakages to straps, or consequential damage from this, as a result of fraying/breaking of the straps, or incorrect use. Please ensure that all bodywork of the motorcycle which may come in contact with the straps (e.g. plastic panels, exhausts, swingarms) are protected or left completely clear of the straps.
- While we may show certain applications where the product is being used for attaching luggage to a motorcycle, this is not a general recommendation and cannot be achieved on all motorcycles.
- Care and attention needs to be taken whenever the product is in use for securing luggage or for tying the motorcycle down. R&G cannot accept any responsibility for inappropriate use or decisions on the part of the user. If in doubt, always consult a professional.

ISSUE 3 18/04/2017 (AR)

**Digital copies of these instructions are available to download from [www.rg-racing.com](http://www.rg-racing.com)**

#### **CONSUMER NOTICE**

The catalogue description and any exhibition of samples are only broad indications of the Products and R&G may make design changes which do not diminish their performance or visual appeal and supplying them in such state shall conform to the order. The Buyer acknowledges no representation or warranty (other than as to title) has been given or will apply to the Products other than those in R&G's order or confirmation and the Buyer confirms it has chosen the Products as being of merchantable quality and suitable for its particular purposes. Where R&G fits the Products or undertakes other services it shall exercise reasonable skill and care and rectify any fault free of charge unless the workmanship has been disturbed. The Buyer is responsible for ensuring that the warranty on the motorcycle is not affected by the fitting of the Products. On return of any defective Products R&G shall at its option either supply a replacement or refund the purchase money but shall not be liable if the Products have been modified or used or maintained otherwise than in accordance with R&G's or manufacturer's instructions and good engineering practice or if the defect arises from accident or neglect. Other than identified above and subject to R&G not limiting its liability for causing death and personal injury, it shall not be liable for indirect or consequential loss and otherwise its liability shall be limited to the amounts paid by the Buyer for the Products or the fitting or service concerned. These terms do not affect the Buyer's statutory rights.

#### **R&G RACING RETURNS POLICY (NON-FAULTY GOODS)**

Returns must be pre-authorized (if not pre-authorized the return will be rejected). Goods may only be returned direct to us if they were purchased direct from us (customer must prove if necessary). Otherwise to be returned to original vendor. Goods must be in re-sellable condition, in the opinion of R&G Racing. All returns are subject to a 25% restocking and handling fee (25% of the gross value exc. P&P – at the prevailing price at time of purchase). The customer must pay any and all carriage charges. No returns of discontinued products, unless within 14 days of purchase. This policy does not affect your statutory rights and does not refer to faulty goods.



**NOTICE DE MONTAGE POUR TH0002**  
**CROCHETS DE TRANSPORT POUR DUCATI PANIGALE (TOUS MODELES)**



**Le kit contient les articles exposés ci-dessous, vérifier que toutes les pièces soient présentes avant de procéder au montage.**

**La façon dont le kit est emballé ne correspond pas forcément à la façon de monter les pièces sur la moto.**

**LES PARTIES PRESENTEES PEUVENT ETRE UNIQUEMENT REPRESENTATIVES (POUR LA CLARTE DES INSTRUCTIONS UNIQUEMENT)**

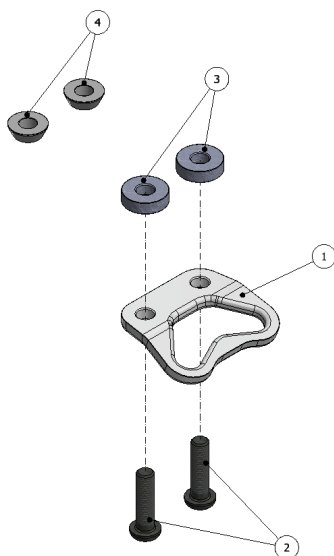

R&G Racing

Unit 1, Shelley's Lane, East Worldham, Alton, Hampshire, GU34 3AQ

Tel: +44 (0)1420 89007 Fax: +44 (0)1420 87301 [www.rg-racing.com](http://www.rg-racing.com) Email: [info@rg-racing.com](mailto:info@rg-racing.com)



### **LEGENDE**

- 1 = CROCHET DE TRANSPORT (SMW0059) (x1).  
 2 = M8 x 30mm BOULON A TETE PLATE (x2).  
 3 = ENTRETOISES (S0623 – 6mm DE LONG) (x2).  
 4 = ENTRETOISES (S0940 – 6mm DE LONG) (x2). \*POUR ETRE UTILISE SUR 959 LORSQUE VOUS N'UTILISEZ PAS LE SUPPORT D'ECHAPPEMENT  
 5 = M8 x 20mm BOULON A TETE PLATE (x2). (NON INDIQUE) \*POUR UTILISER SUR 899 SEULEMENT A LA PLACE DES BOULONS A TETE PLATE M8 x 30mm.

Notez que si les kits sont emballés avec des rondelles en caoutchouc servant à tenir les composants, ces rondelles doivent être jetées.

### **OUTILS REQUIS**

- Jeu de clés à douille 5 & 6mm et extensions.
- Jeu de clés 12mm (uniquement sur 959).

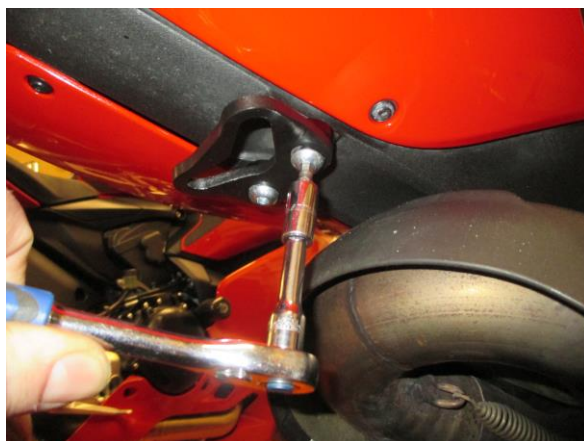

Photo 1



Photo 2



Photo 3



### COUPLES DE SERRAGE RECOMMANDÉS

M4 BOULON = 8Nm  
 M5 BOULON = 12Nm  
 M6 BOULON = 15Nm  
 M8 BOULON = 20Nm  
 M10 BOULON = 40Nm

### NOTICE DE MONTAGE

#### **Si installation sur 1199 & 1299**

- Positionnez les 2 boulons à tête plate M8 x 30mm dans les 2 trous de fixation du crochet de transport (SMW0059) (*en veillant à ce que la partie se penche vers l'extérieur de la moto*) puis dans les 2 entretoises (3 – S0623 – 6mm de long), voir le schéma page 1.
- Prendre l'ensemble et montez le sur la moto, avant de serrer légèrement les 2 boulons dans les 2 trous du sous cadre au dessous du siège, voir photos 1 & 2.
- Veiller à ce que la partie soit correctement montée avant de serrer les 2 boulons aux couples de serrage recommandés.

#### **Si installation sur 899**

- Positionner les 2 boulons à tête plate M8 x 20mm dans les 2 trous de fixation du crochet de transport (SMW0059) (*en veillant à ce que la partie se penche vers l'extérieur de la moto*) puis dans les 2 entretoises (3 – S0623 – 6mm de long), voir le schéma page 1.
- Prendre l'ensemble et montez le sur la moto, avant de serrer légèrement les 2 boulons dans les 2 trous du sous cadre au dessous du siège, voir photos 1 & 2.
- Veiller à ce que la partie soit correctement montée avant de serrer les 2 boulons aux couples de serrage recommandés.

#### **Si installation sur 959 avec support d'échappement**

- Enlever les 2 boulons les plus reculés du support d'échappement et montez le crochet de transport en position (*en veillant à ce que la partie se penche vers l'extérieur de la moto*) avant d'insérer les 2 boulons M8 x 30mm dans les 2 trous de fixation du crochet de transport et support d'échappement, avant de serrer dans les 2 trous filetés au dessous du siège, voir photo 3.
- Veiller à ce que la partie soit correctement montée avant de serrer les 2 boulons aux couples de serrage recommandés.

#### **Si installation sur 959 sans support d'échappement**

- Si vous enlevez le support de fixation repose pied et ne remontez pas le support d'échappement, utilisez les 2 entretoises fournies (4 – S0940 – 6mm de long) et placez les entre le bouclier de protection chaleur et les supports de sous cadre avant, puis serrer avec les boulons d'origine.
- Insérer les 2 boulons à tête plate M8 x 30mm dans les 2 trous de fixation du crochet de transport (SMW0059) (*en veillant à ce que la partie se penche vers l'extérieur de la moto*) puis dans les 2 entretoises (3 – S0623 – 6mm de long), voir sur le schéma page 1.
- Prendre l'ensemble et montez le sur la moto, avant de serrer légèrement les 2 boulons à tête plate dans les 2 trous du sous cadre au dessous du siège, voir photos 1 & 2.
- Veiller à ce que la partie soit correctement montée avant de serrer les 2 boulons aux couples de serrage recommandés..

- Nous recommandons que le tissu des sangles soit en contact avec le produit, Par opposition au crochet sur l'extrémité de la sangle.. Cela augmente la durée de vie du revêtement protecteur présent sur le produit.

R&G Racing

Unit 1, Shelley's Lane, East Worldham, Alton, Hampshire, GU34 3AQ

Tel: +44 (0)1420 89007 Fax: +44 (0)1420 87301 [www.rg-racing.com](http://www.rg-racing.com) Email: [info@rg-racing.com](mailto:info@rg-racing.com)



- Ne pas trop serrer les sangles attachées au produit, car cela pourrait plier ou casser le produit avec si la force est excessive. En cas de doute, consulter un professionnel.
- R & G ne peut être tenu pour responsable des bris de sangles, ou des dommages consécutifs à cela, en raison de l'effilochage / rupture des sangles, ou de l'utilisation incorrecte. Veillez à ce qu'aucune partie de la moto ne puisse entrer en contact avec les sangles (par exemple les panneaux en plastique, les échappements, les bras oscillants) et soit protégée ou laissée complètement à l'écart des sangles.
- Bien que nous puissions montrer certaines applications où le produit est utilisé pour attacher des bagages à une moto, ce n'est pas une recommandation générale, elle ne peut donc pas être réalisée sur toutes les motos.

Des précautions doivent être prises lorsque le produit est utilisé pour sécuriser les bagages ou pour attacher la moto. R&G décline toute responsabilité en cas d'utilisation inappropriée ou de décision inappropriée de la part de l'utilisateur. En cas de doute, consultez toujours un professionnel.

ISSUE 3 08/04/2017 (AR)

**Notice disponible au téléchargement sur [www.rg-racing.com](http://www.rg-racing.com)**

#### CONSUMER NOTICE

The catalogue description and any exhibition of samples are only broad indications of the Products and R&G may make design changes which do not diminish their performance or visual appeal and supplying them in such state shall conform to the order. The Buyer acknowledges no representation or warranty (other than as to title) has been given or will apply to the Products other than those in R&G's order or confirmation and the Buyer confirms it has chosen the Products as being of merchantable quality and suitable for its particular purposes. Where R&G fits the Products or undertakes other services it shall exercise reasonable skill and care and rectify any fault free of charge unless the workmanship has been disturbed. The Buyer is responsible for ensuring that the warranty on the motorcycle is not affected by the fitting of the Products. On return of any defective Products R&G shall at its option either supply a replacement or refund the purchase money but shall not be liable if the Products have been modified or used or maintained otherwise than in accordance with R&G's or manufacturer's instructions and good engineering practice or if the defect arises from accident or neglect. Other than identified above and subject to R&G not limiting its liability for causing death and personal injury, it shall not be liable for indirect or consequential loss and otherwise its liability shall be limited to the amounts paid by the Buyer for the Products or the fitting or service concerned. These terms do not affect the Buyer's statutory rights.

#### R&G RACING RETURNS POLICY (NON-FAULTY GOODS)

Returns must be pre-authorized (if not pre-authorized the return will be rejected). Goods may only be returned direct to us if they were purchased direct from us (customer must prove if necessary). Otherwise to be returned to original vendor. Goods must be in re-sellable condition, in the opinion of R&G Racing. All returns are subject to a 25% restocking and handling fee (25% of the gross value exc. P&P – at the prevailing price at time of purchase). The customer must pay any and all carriage charges. No returns of discontinued products, unless within 14 days of purchase. This policy does not affect your statutory rights and does not refer to faulty goods.